

DINGS

Precision Motion Specialist

MICRO RADIAL BLDC BLOWER PRODUCT CATALOG

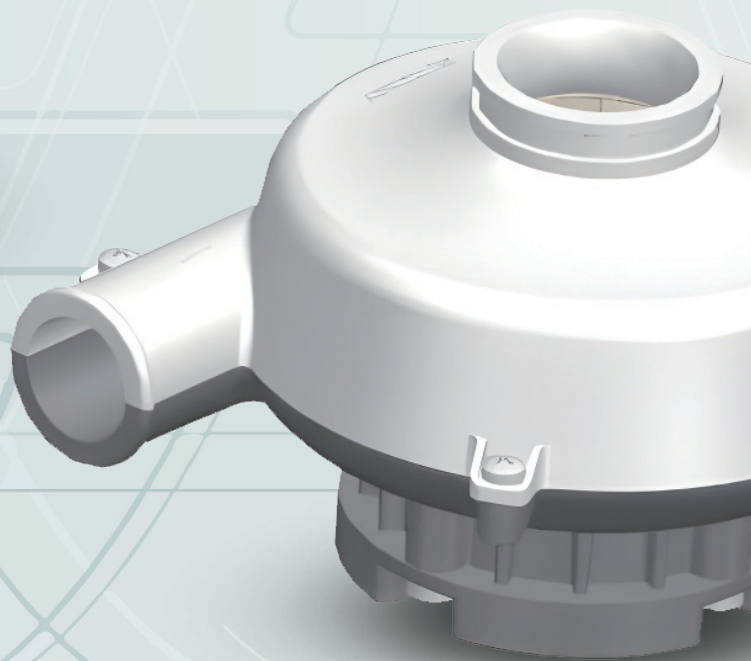

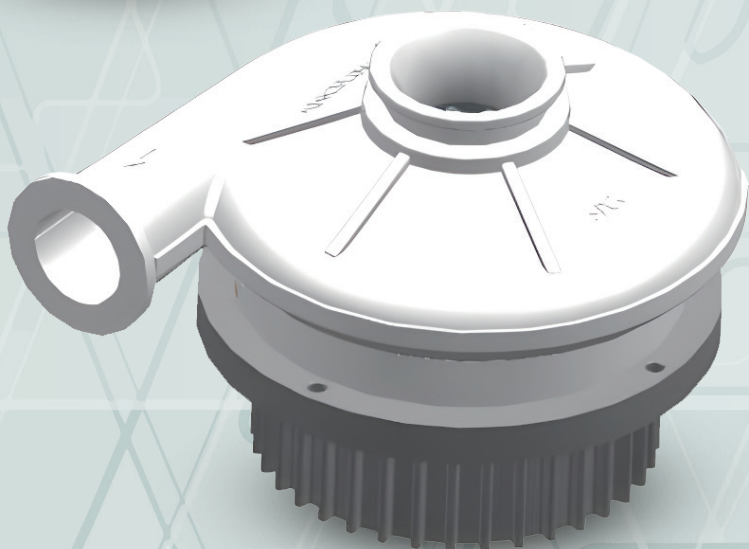

DETAILS make the SUCCESS

Since its establishment in 2008, Jiangsu DINGS' Intelligent Control Technology Co., Ltd adheres to the

"Quality comes from Responsibility, Details determine Success or Failure" business concept, commits to become a Precision Motion Specialist and world-class motion control solutions provider.

DINGS' provides precision stepper motor actuators, brushless DC motors and motion controllers.

SIZE

DINGS' facility covers an area of 56 acres, with more than 5,000 square meters of processing center, equipped with more than 100 sets of processing equipment such as wire rolling machine, automatic injection molding machine, CNC machine tools, machining centers, automatic screw straightening machine, etc., with a total investment of more than 100 million in equipment; there are more than 20 motor assembly lines in the production workshop, with an annual production capacity of up to 4 million units; and there is a product research and development center, a precision testing and inspection laboratory and an experimental center.

It is equipped with testing and inspection instruments such as positioning torque test, hardness test, precision measurement, dynamic balance, etc. It has an integrated management system of product design, manufacturing and inspection, which provides the necessary conditions to meet the customized demands of users.



GROWTH

2008	Established a company and registered DINGS' Brand
2010	Established DINGS' MOTION USA
2016	Established DINGS' Korea
2019	Join in LEILI group
2021	Established Changzhou Intelligent Manufacturing Factory Listed on the new third board, NEEQ stock market
2022	Set up R&D Center in Korea Listed on the Beijing Stock Exchange [Stock Code : 873593]
2023	Establishment of DINGS' Europe Conversion to DINGS' Korea Corporation Establishment of DINGS' Japan
2024	Relocation of Headquarter into new plant

QUALIFICATIONS

DINGS' is a high-tech company listed on the new third board, NEEQ stock market in June, 2021. And listed on the Beijing Stock Exchange 13th Apr, 2023. DINGS' has awards of "Jiangsu Private Science and Technology Enterprise", "Jiangsu Science and Technology Small and Medium-sized Enterprise" and "Jiangsu Specialized and New Small Giant Enterprise". In addition, DINGS' products have RoHS, CE, REACH and other certifications as ISO9001 and ISO14001. DINGS' has more than 80 invention patents.

PRODUCT WARRANTY STATEMENT

DINGS' provides product quality certificates during shipping, and customers are to inspect product according to technical drawings and/or related requirements.

DINGS's product warranty period is 2 years, calculated from delivery date, and customers are to refer to the product manual for proper storage and usage of the product.

During the service life or warranty period, if our products are damaged or do not work properly due to quality problems, DINGS' provides no-charge repairs.

The following conditions do not belong to the scope of free maintenance :

- When the validity period has been exceeded
(In the case of loss of nameplate or artificial damage, it is considered to have exceeded the validity period)
- Damage caused by improper usage
- Man-made dismantling
- Products that have been disassembled or repaired, but not by a DINGS' accredited representative
- Failure caused by irresistible factors such as natural disasters



MICRO RADIAL BLDC BLOWER

CONTENTS



- Company Overview
- Application Field And Scenarios
- Blowers
 - C60 Series Blowers
 - C80 Series Blowers
 - C90 Series Blowers
 - S80 Series Blowers
 - Blower Accessories
- Certificates



Company Overview

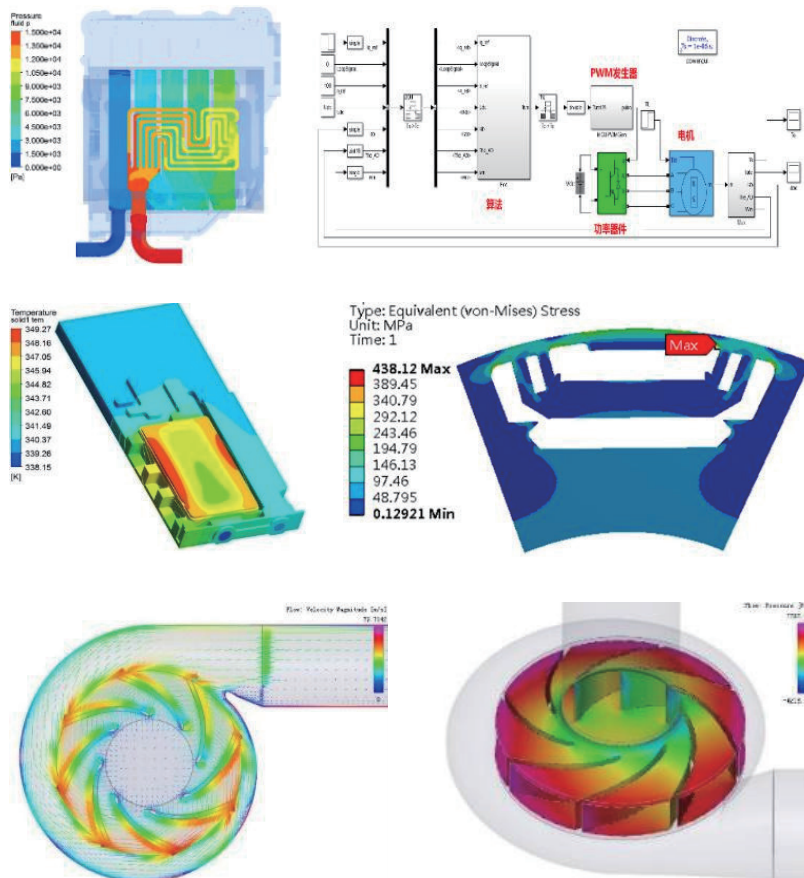

Product Development Capabilities

- System Definition and System Integration
- Fluid Design
- Electrical Motor Development
- Motor Driver HW&SW Development
- Mechanical Design
- FEA/CFD/Electromagnetic/Thermal Simulation
- Completed Product Validation Capabilities

Product Portfolios

- Brushless DC Blower
- Brushless DC Motor Driver
- Brushless DC Motor
- Fuel Cell Air Compressor

DINGS' Micro Radial BLDC Blower Motor Key Features

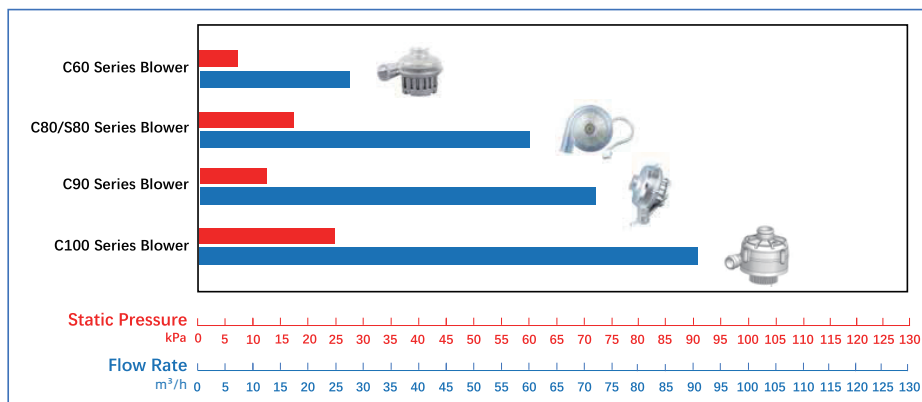

High Static Pressure

Compact Design

Speed: 30,000-120,000rpm

Low Noise

>20,000h/50,000h
Long Life

Why Choose Us



We are the fluid product expert

- Average 10+ years R&D experience, core members hold PHD and Master's degrees
- Rich experience in system development and system integration
- Expertise in blower, fan, brushless DC motor and motor driver development
- Automotive manufacturing expertise team
- High static pressure and air flow-rate in a compact size, combining silence technology and fast dynamic response design



Customizable

- DINGS' engineering team develops the desired application with and for the customer according to individual requirements



Long Service Life

- The expected lifetime of our fans and blowers is more than 20,000 to 50,000 hours, which means high reliability for the operator



Reliable Quality

- Strictly following ISO 9001 and company quality policy, we always offer high-quality and excellent consistency products to our customers.



Competitive Price

- Conducting fit-for-use design, lean manufacturing and craftsmanship policy, we can offer our customers with a competitive price



Quick Technical Support

- We have a fast-response technical expertise team; our customers can easily get professional technical support from us

Application Field And Scenarios

Main Application Filed

Medical & Big Health



Hydrogen Fuel Cell System



Industrial Automation Test & Monitoring Equipment



Special Applications



Typical Application Scenarios

Medical	Equipment and Instrument	Others
<ul style="list-style-type: none"> ■ Ventilator ■ Expectorator machine ■ Surgical smoke removal equipment ■ Nebulizer ■ Oxygen generator ■ Isolation chamber ■ PARR ■ Dental equipment ■ Disinfection and sterilization equipment ■ Gas test 	<ul style="list-style-type: none"> ■ Dust/Smoking removal ■ Disinfection and sterilization equipment for cold chain ■ Cooling ■ Glove box ■ Temperature and humidity test chamber ■ Part grabbing ■ Gas transportation ■ Liquid nebulizer ■ Environmental monitoring ■ Gas test 	<ul style="list-style-type: none"> ■ Hydrogen fuel cell system ■ Fresh air system ■ Vacuum cleaner ■ Floor sweeping robot ■ Air cushion aerator ■ Moxibustion smoking removal ■ Agricultural application ■ Aerator ■ Stove
· · ·	· · ·	· · ·

The Model Definition of DINGS' Micro Radial BLDC Blower

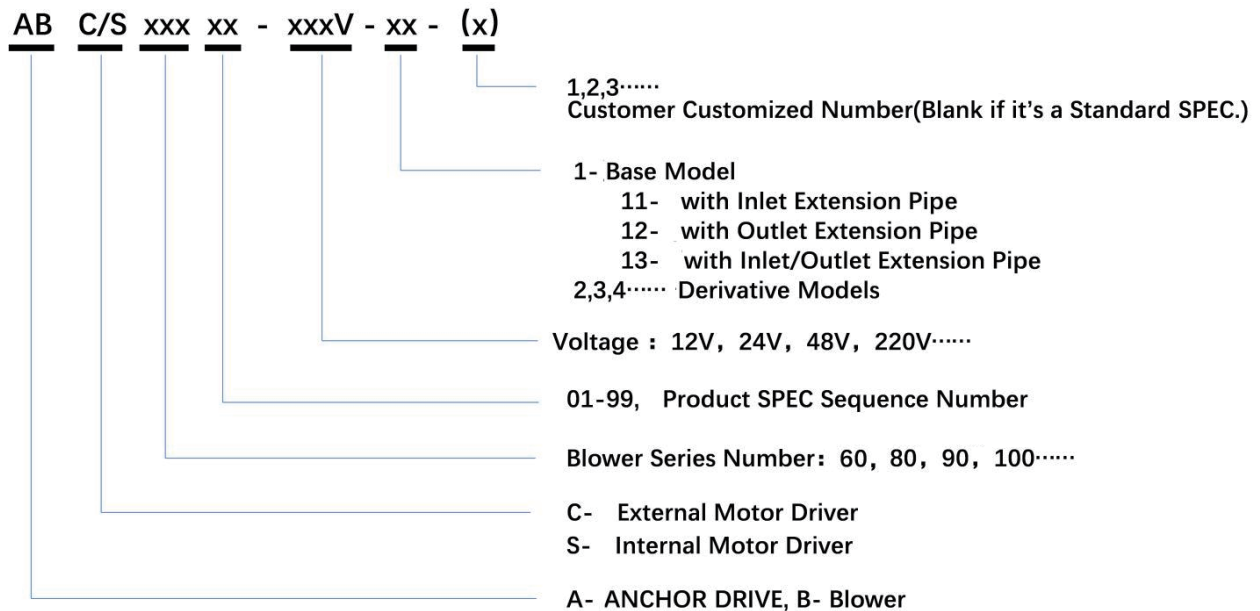

Example

AB C8007-24V-1	AB C8007-24V-2	Base model
AB C8007-24V-11	AB C8007-24V-21	w/ Inlet Extension Pipes
AB C8007-24V-12	AB C8007-24V-22	w/ Outlet Extension Pipes
AB C8007-24V-13	AB C8007-24V-23	w/ Inlet & Outlet Extension Pipes

Table 1- The Comparison Matrix of AB C80xx-1 and AB C80xx-2

	Function/Performance Comparison	AB C8007-24V-1	AB C8007-24V-2
1	Functions		Same
2	Performance		Same
3	Lifetime		Same
4	Voltage Range		Same
5	Max.Current		Same
6	Size		Same
7	Mass	310g	330g
8	Work Temperature	-20°C~50°C	-30°C~50°C
9	Humidity	≤85%RH	≤95%RH
10	Acid-Resisting	No	Yes
11	Corrosion Preventive	No	Yes

Series Name

C60

Motor Simplified Name

C6001



PRODUCT PARAMETERS

Item Name	C6001
Brand Name	ANCFLOW
Model Number	C6001-12/24V-1/3
Part Name	Brushless DC Blower
Rated Power (W)	50
Rated Voltage (V)	12/24
Power Supply Type	DC
Driver Layout	External
max.Static Pressure	7.0 kPa
max.Flow Rate	450LPM (27.0m ³ /h)
Rated Static Pressure	5.5kPa
Rated Flow Rate	202LPM (12.1m ³ /h)
Temperature Range(ambient)	-20°C~+50°C
Humidity Range(ambient)	≤85%RH
Size	60.5*76.0*55.0mm/60.5*76.0*48.0mm
Service life (L10 at 40)	20,000h
Certification	RoHS, CE
Application Field	medical smoke removal equipment, ventilator, hydrogen fuel cell, cold chain sterilization equipment, disinfection and sterilization equipment, oxygen generator, dental equipment, negative pressure isolation chamber, PARR, moxibustion smoking, household fresh air system, temperature and humidity control, environmental monitoring equipment, gas detector, air cushion aerator, glove box, industrial smoke/dust removal equipment, liquid atomization, cooling and drying equipment, agricultural machinery, fishery aerator, etc.

■ PERFORMANCE CURVES

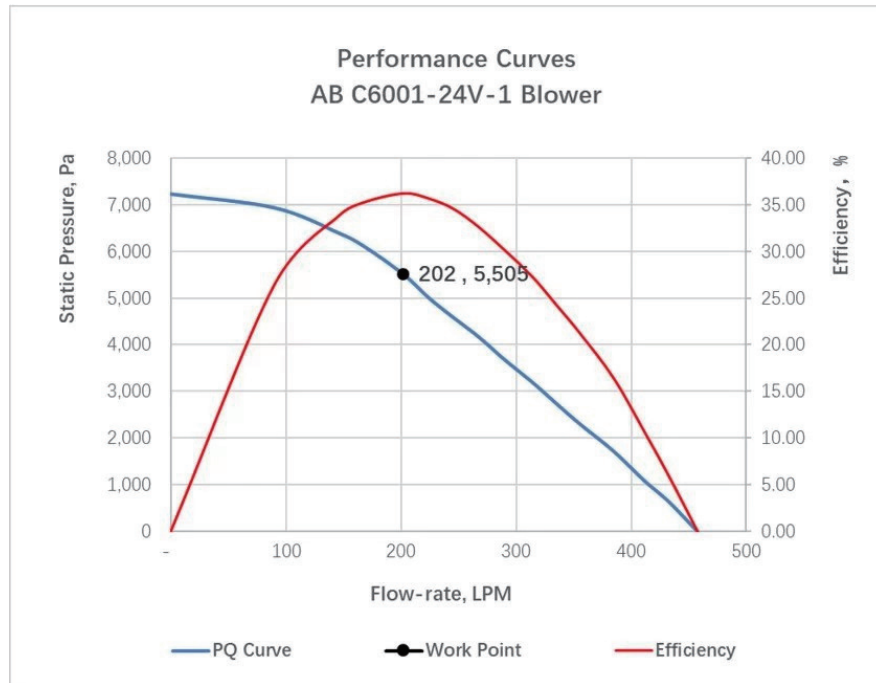

■ INTERFACE DRAWING

C60-1/C60-2 Series

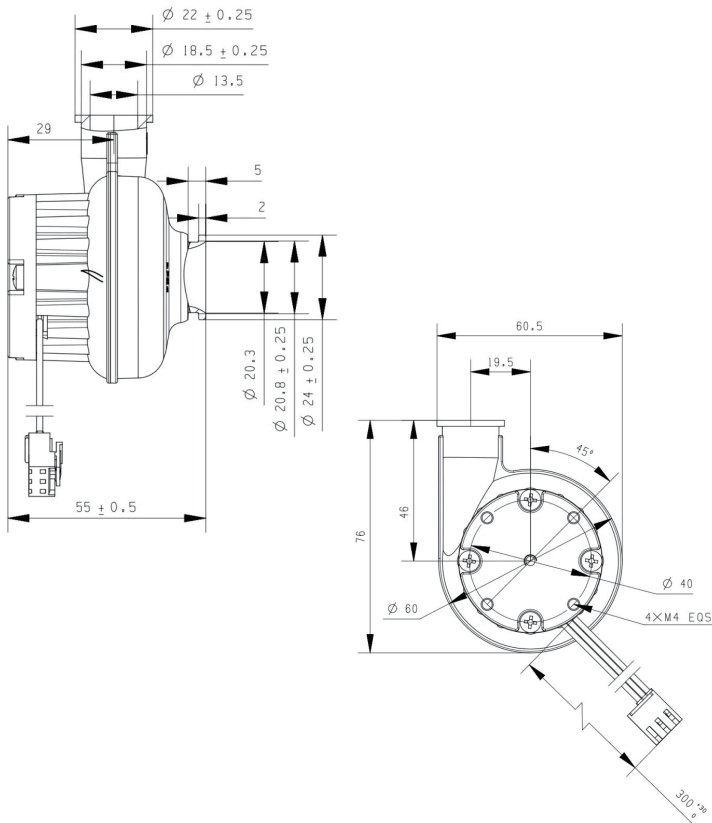

C60-3/C60-4 Series

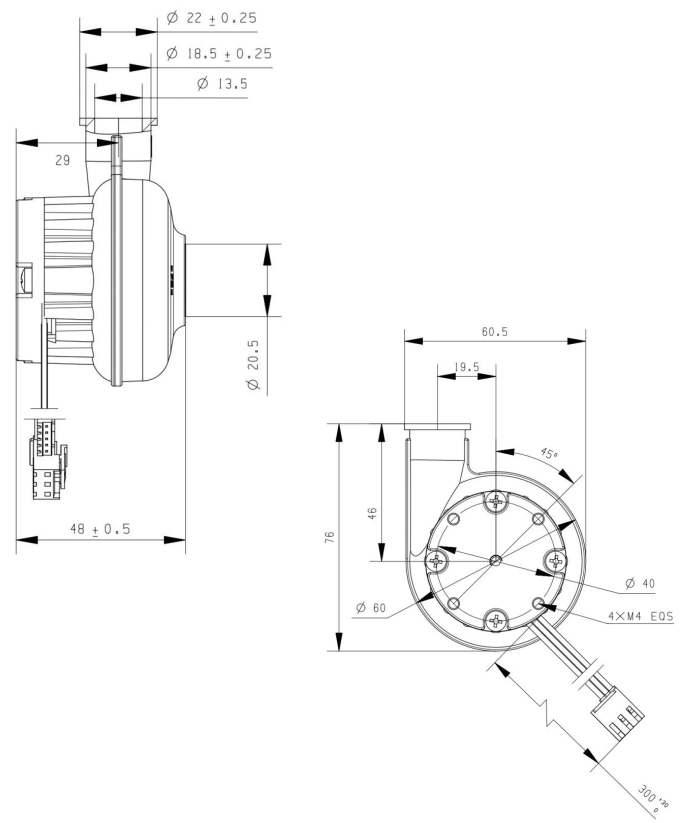

Series Name

C60

Motor Simplified Name

C6002



PRODUCT PARAMETERS

Item Name	C6002
Brand Name	ANCFLOW
Model Number	C6002-12/24/48V-1/3
Part Name	Brushless DC Blower
Rated Power (W)	50
Rated Voltage (V)	12/24/48
Power Supply Type	DC
Driver Layout	External
max.Static Pressure	7.0 kPa
max.Flow Rate	450LPM (27.0m ³ /h)
Rated Static Pressure	5.5kPa
Rated Flow Rate	200LPM (12.1m ³ /h)
Temperature Range(ambient)	-20°C~+50°C
Humidity Range(ambient)	≤85%RH
Size	60.5*76.0*55.0mm/60.5*76.0*48.0mm
Service life (L10 at 40)	20,000h
Certification	RoHS, CE
Application Field	medical smoke removal equipment, ventilator, hydrogen fuel cell, cold chain sterilization equipment, disinfection and sterilization equipment, oxygen generator, dental equipment, negative pressure isolation chamber, PARR, moxibustion smoking, household fresh air system, temperature and humidity control, environmental monitoring equipment, gas detector, air cushion aerator, glove box, industrial smoke/dust removal equipment, liquid atomization, cooling and drying equipment, agricultural machinery, fishery aerator, etc.

■ PERFORMANCE CURVES

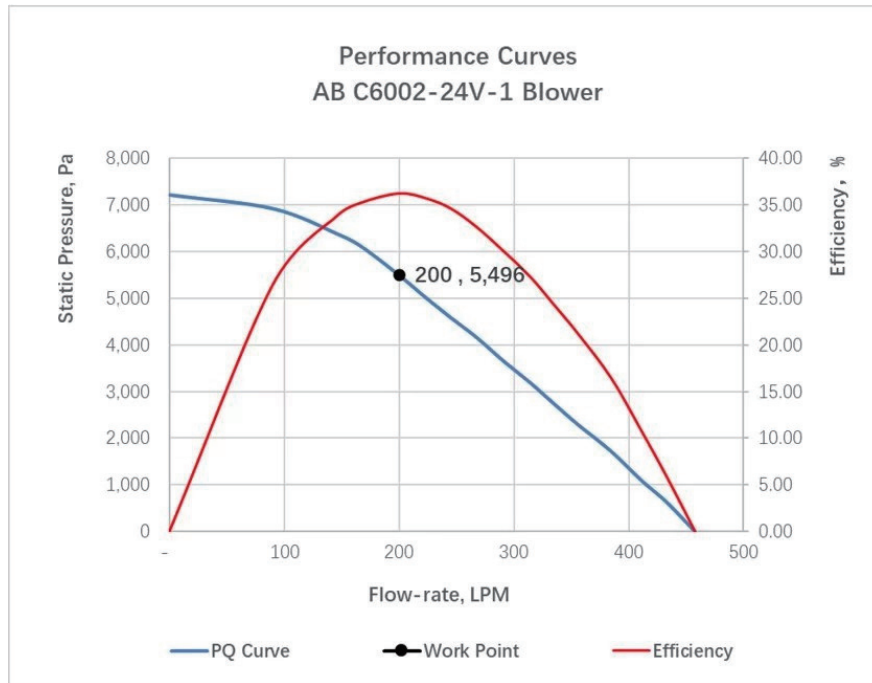

■ INTERFACE DRAWING

C60-1/C60-2 Series

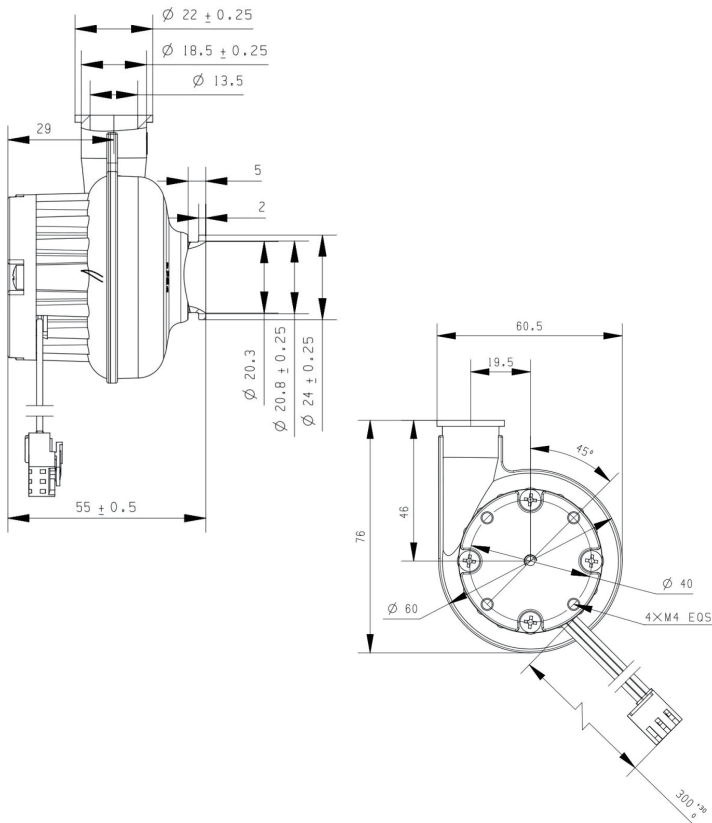

C60-3/C60-4 Series

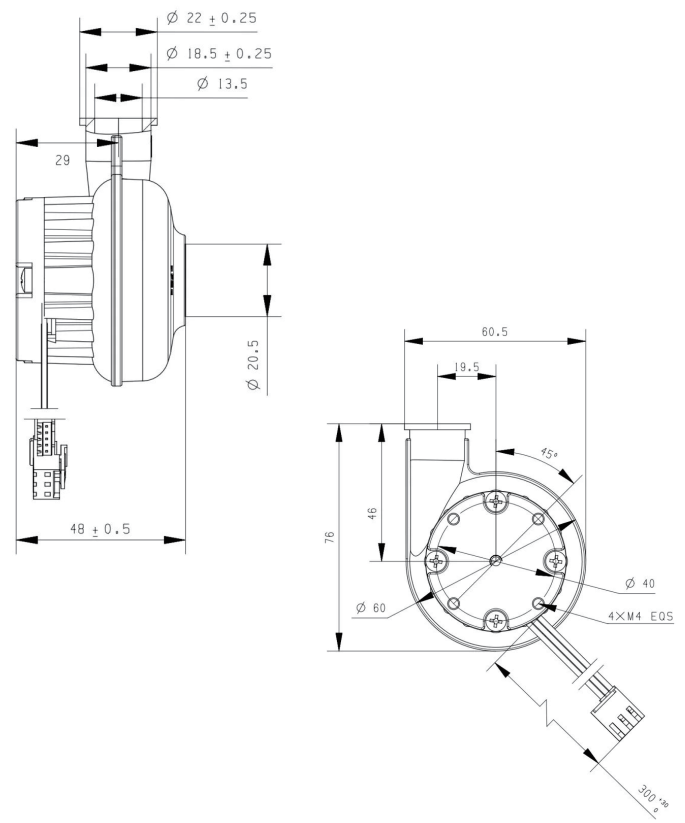

Series Name

C60

Motor Simplified Name

C6006



PRODUCT PARAMETERS

Item Name	C6006
Brand Name	ANCFLOW
Model Number	C6006-12/24/48V-1/3
Part Name	Brushless DC Blower
Rated Power (W)	34
Rated Voltage (V)	12/24/48
Power Supply Type	DC
Driver Layout	External
max.Static Pressure	5.3kPa
max.Flow Rate	422LPM (25.3m ³ /h)
Rated Static Pressure	4.0kPa
Rated Flow Rate	161LPM (9.6m ³ /h)
Temperature Range(ambient)	-20°C~+50°C
Humidity Range(ambient)	≤85%RH
Size	60.5*76.0*55.0mm/60.5*76.0*48.0mm
Service life (L10 at 40)	20,000h
Certification	RoHS, CE
Application Field	medical smoke removal equipment, ventilator, hydrogen fuel cell, cold chain sterilization equipment, disinfection and sterilization equipment, oxygen generator, dental equipment, negative pressure isolation chamber, PARR, moxibustion smoking, household fresh air system, temperature and humidity control, environmental monitoring equipment, gas detector, air cushion aerator, glove box, industrial smoke/dust removal equipment, liquid atomization, cooling and drying equipment, agricultural machinery, fishery aerator, etc.

■ PERFORMANCE CURVES

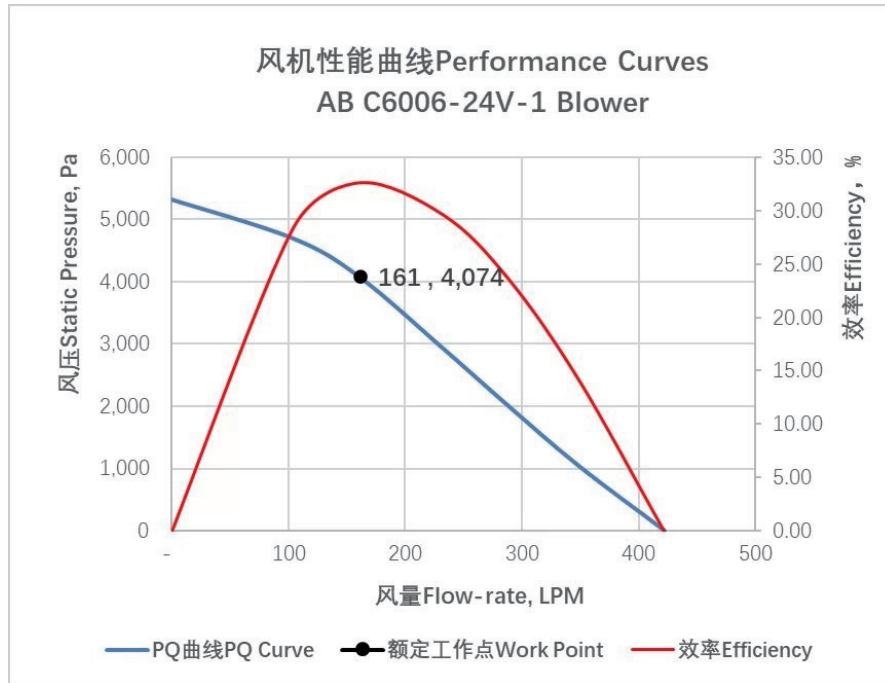

■ INTERFACE DRAWING

C60-1/C60-2 Series

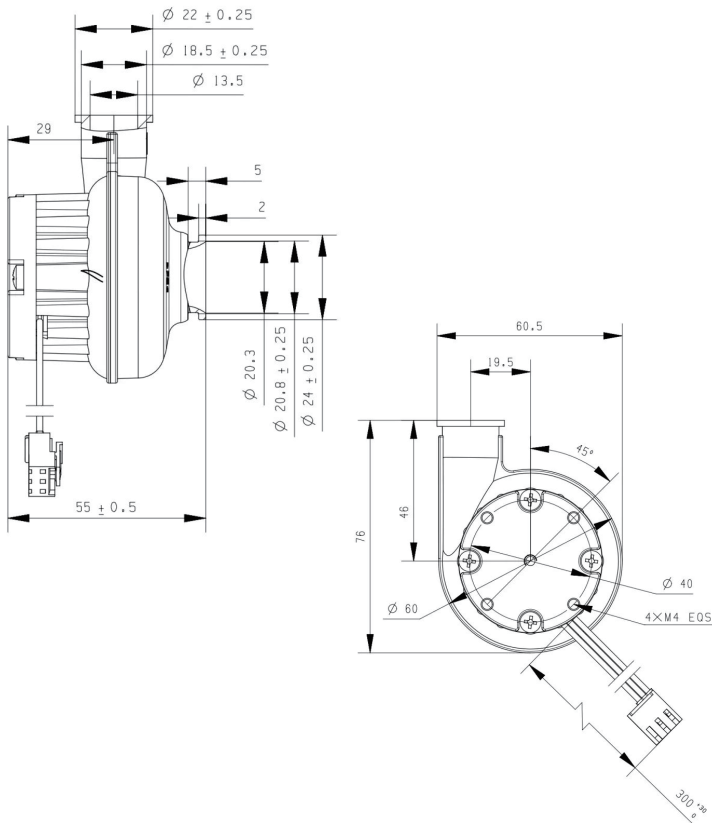

C60-3/C60-4 Series

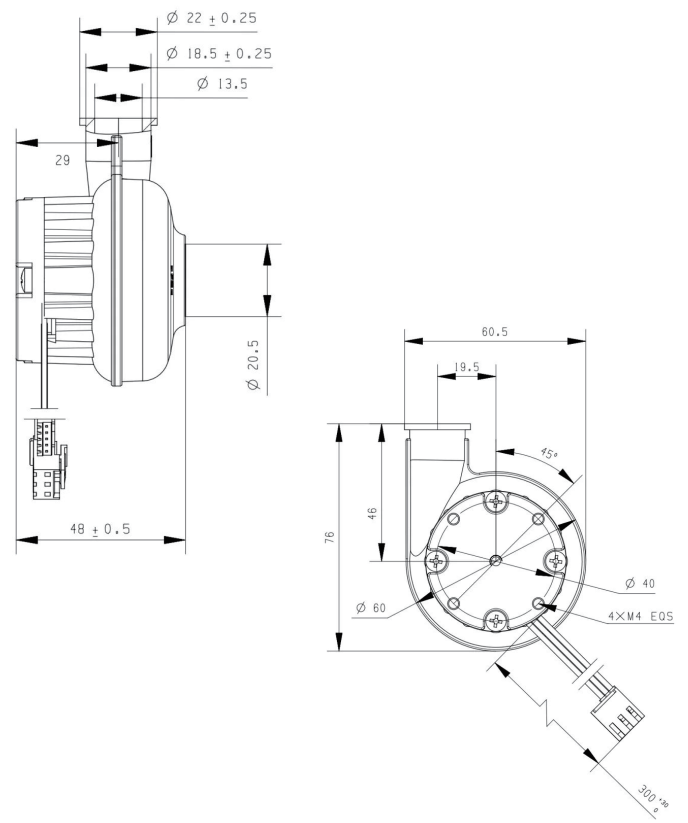

Series Name

C60

Motor Simplified Name

C6008



PRODUCT PARAMETERS

Item Name	C6008
Brand Name	ANCFLOW
Model Number	C6008-12/24/48V-1/3
Part Name	Brushless DC Blower
Rated Power (W)	31
Rated Voltage (V)	12/24/48
Power Supply Type	DC
Driver Layout	External
max.Static Pressure	4.5kPa
max.Flow Rate	386LPM (23.2m ³ /h)
Rated Static Pressure	3.1kPa
Rated Flow Rate	181LPM (10.8m ³ /h)
Temperature Range(ambient)	-20°C~+50°C
Humidity Range(ambient)	≤85%RH
Size	60.5*76.0*55.0mm/60.5*76.0*48.0mm
Service life (L10 at 40)	20,000h
Certification	RoHS, CE
Application Field	medical smoke removal equipment, ventilator, hydrogen fuel cell, cold chain sterilization equipment, disinfection and sterilization equipment, oxygen generator, dental equipment, negative pressure isolation chamber, PARR, moxibustion smoking, household fresh air system, temperature and humidity control, environmental monitoring equipment, gas detector, air cushion aerator, glove box, industrial smoke/dust removal equipment, liquid atomization, cooling and drying equipment, agricultural machinery, fishery aerator, etc.

■ PERFORMANCE CURVES

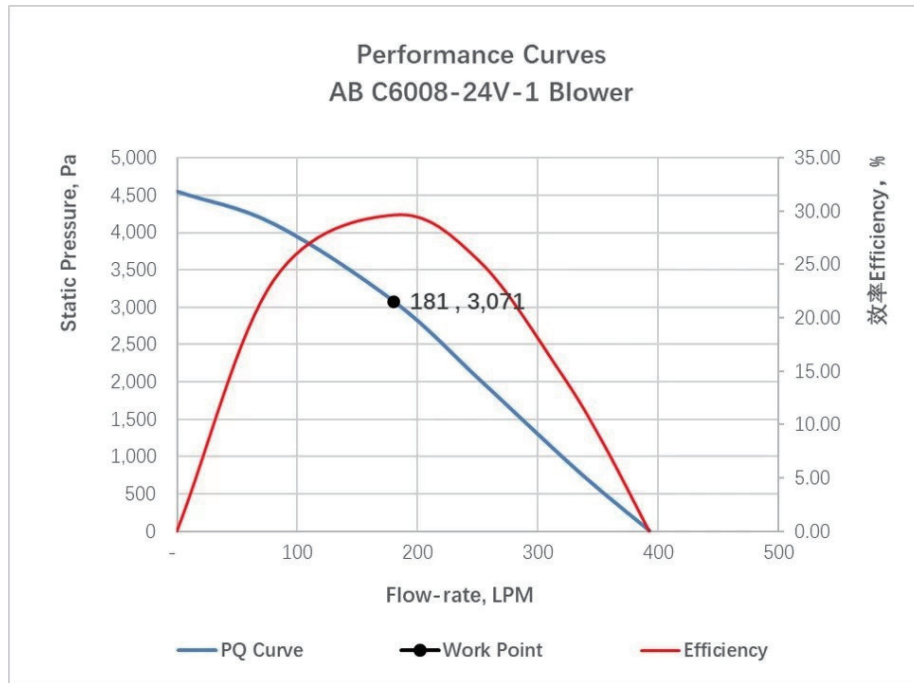

■ INTERFACE DRAWING

C60-1/C60-2 Series

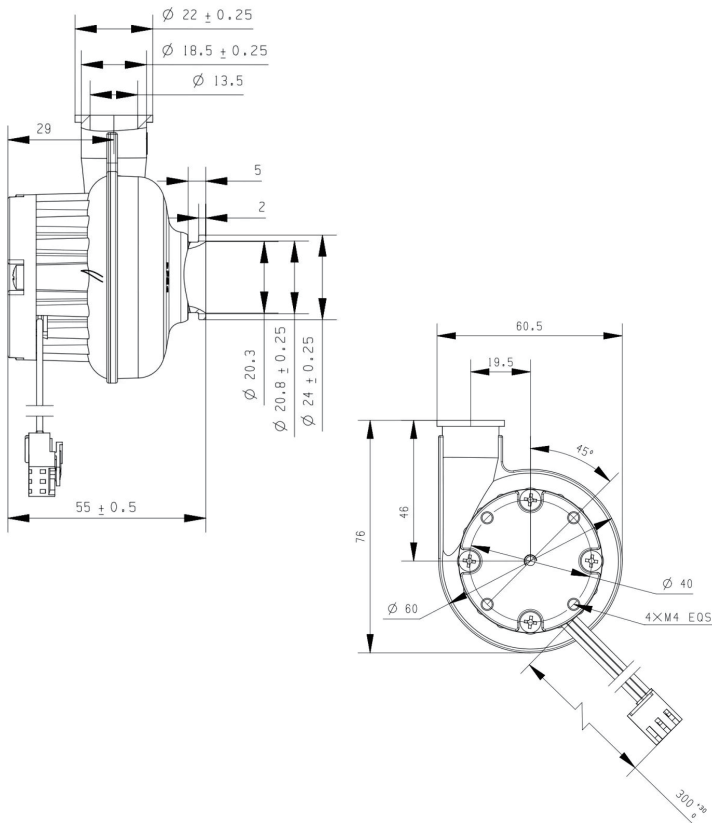

C60-3/C60-4 Series

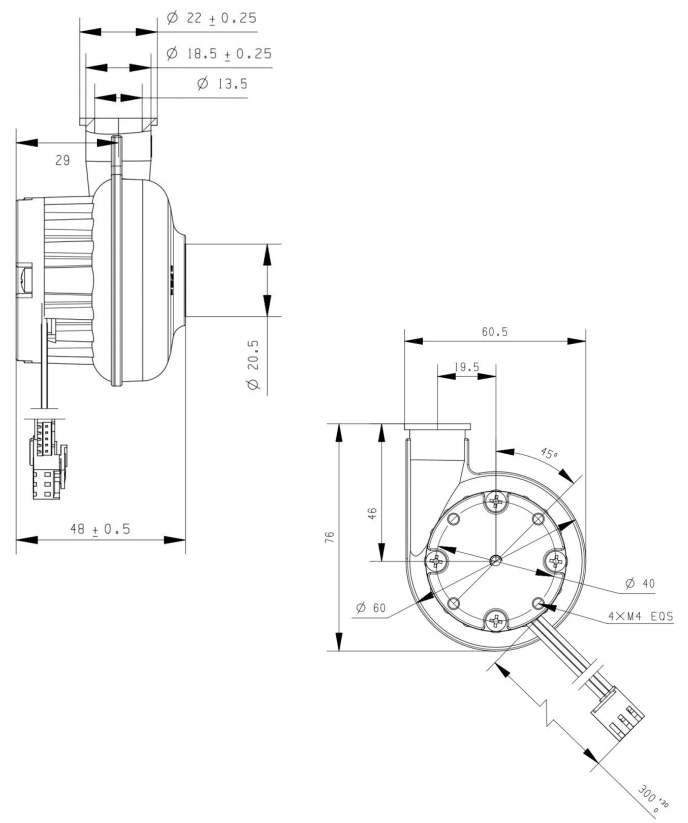

Series Name

C80

Motor Simplified Name

C8001



PRODUCT PARAMETERS

Item Name	C8001
Brand Name	ANCFLOW
Model Number	C8001-24V-1
Part Name	Brushless DC Blower
Rated Power (W)	187
Rated Voltage (V)	24
Power Supply Type	DC
Driver Layout	External
max.Static Pressure	17.0kPa
max.Flow Rate	960LPM (57.6m ³ /h)
Rated Static Pressure	13.0kPa
Rated Flow Rate	430LPM (25.8m ³ /h)
Temperature Range(ambient)	-20°C~+50°C
Humidity Range(ambient)	≤85%RH
Size	85.3*82.2*60.9mm
Service life (L10 at 40)	20,000h
Certification	RoHS, CE, ISO10993
Application Field	medical smoke removal equipment, ventilator, hydrogen fuel cell, cold chain sterilization equipment, disinfection and sterilization equipment, oxygen generator, dental equipment, negative pressure isolation chamber, PARR, moxibustion smoking, household fresh air system, temperature and humidity control, environmental monitoring equipment, gas detector, air cushion aerator, glove box, industrial smoke/dust removal equipment, liquid atomization, cooling and drying equipment, agricultural machinery, fishery aerator, etc.

■ PERFORMANCE CURVES

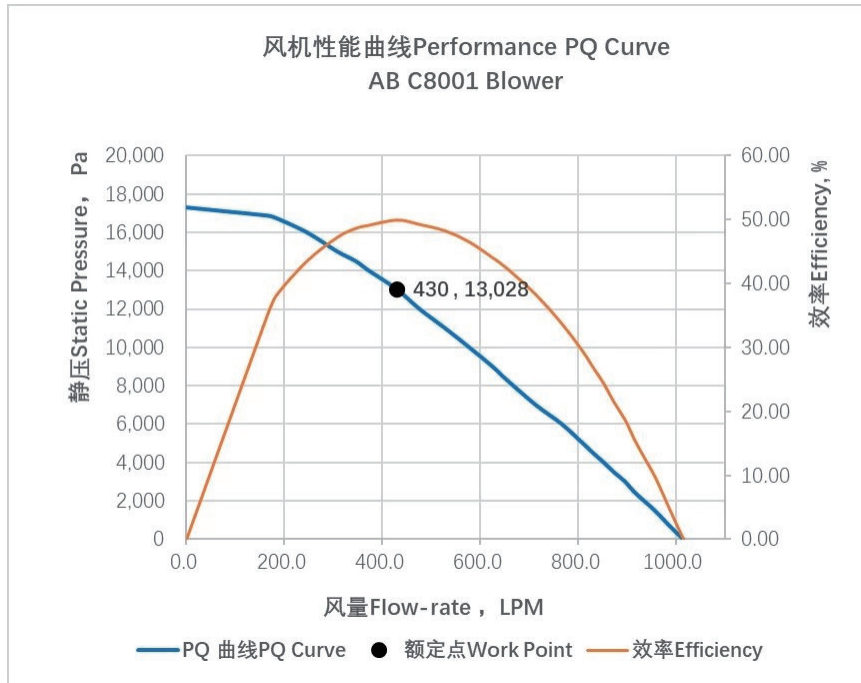

■ INTERFACE DRAWING

C80-1/C80-2 Series

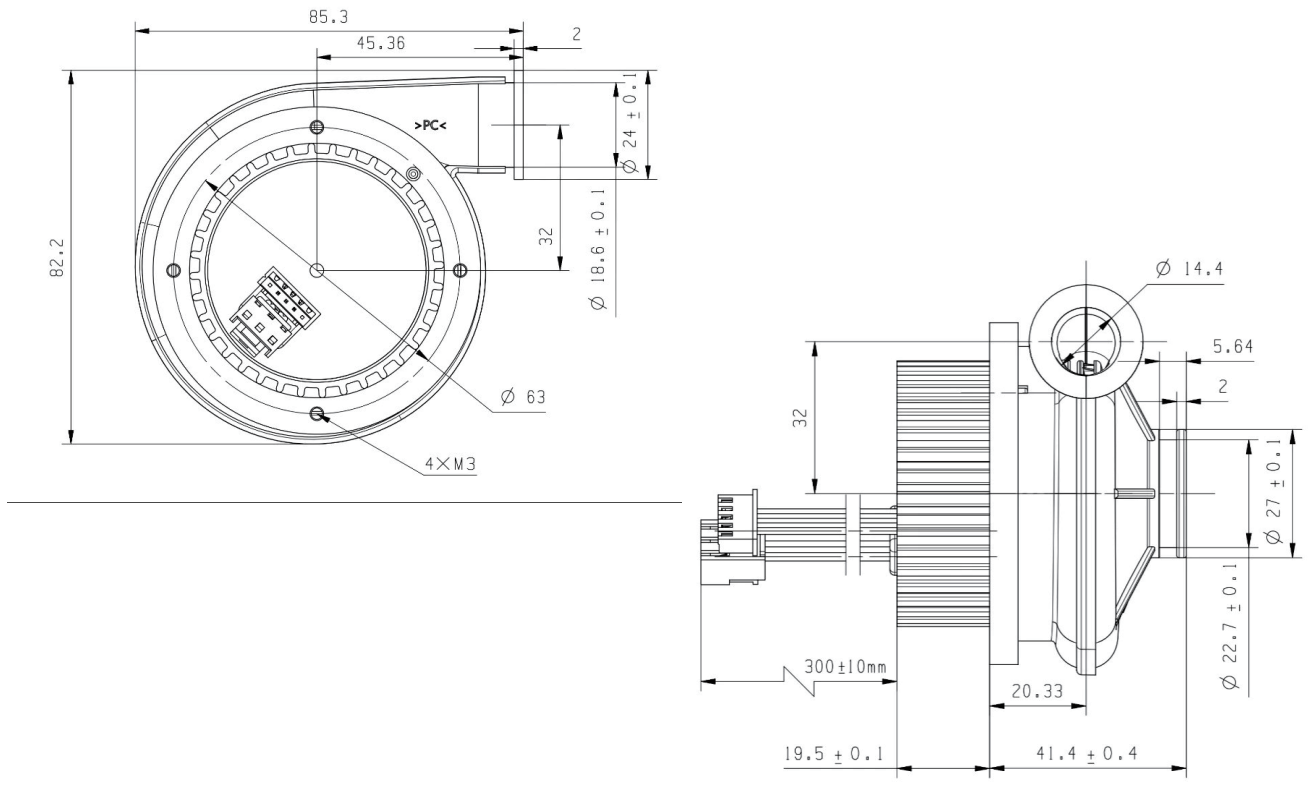

Series Name

C80

Motor Simplified Name

C8002



PRODUCT PARAMETERS

Item Name	C8002
Brand Name	ANCFLOW
Model Number	C8002-24/48V-1
Part Name	Brushless DC Blower
Rated Power (W)	180
Rated Voltage (V)	24/48
Power Supply Type	DC
Driver Layout	External
max.Static Pressure	17.0kPa
max.Flow Rate	960LPM (57.6m ³ /h)
Rated Static Pressure	14.0kPa
Rated Flow Rate	388LPM (23.3m ³ /h)
Temperature Range(ambient)	-20°C~+50°C
Humidity Range(ambient)	≤85%RH
Size	85.3*82.2*60.9mm
Service life (L10 at 40)	20,000h
Certification	RoHS, CE, ISO10993
Application Field	medical smoke removal equipment, ventilator, hydrogen fuel cell, cold chain sterilization equipment, disinfection and sterilization equipment, oxygen generator, dental equipment, negative pressure isolation chamber, PARR, moxibustion smoking, household fresh air system, temperature and humidity control, environmental monitoring equipment, gas detector, air cushion aerator, glove box, industrial smoke/dust removal equipment, liquid atomization, cooling and drying equipment, agricultural machinery, fishery aerator, etc.

■ PERFORMANCE CURVES

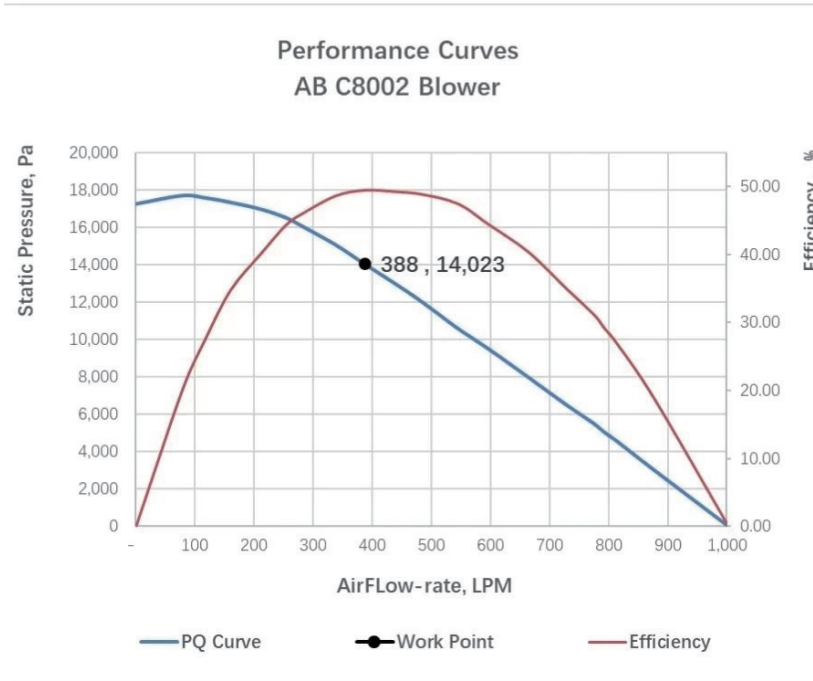

■ INTERFACE DRAWING

C80-1/C80-2 Series

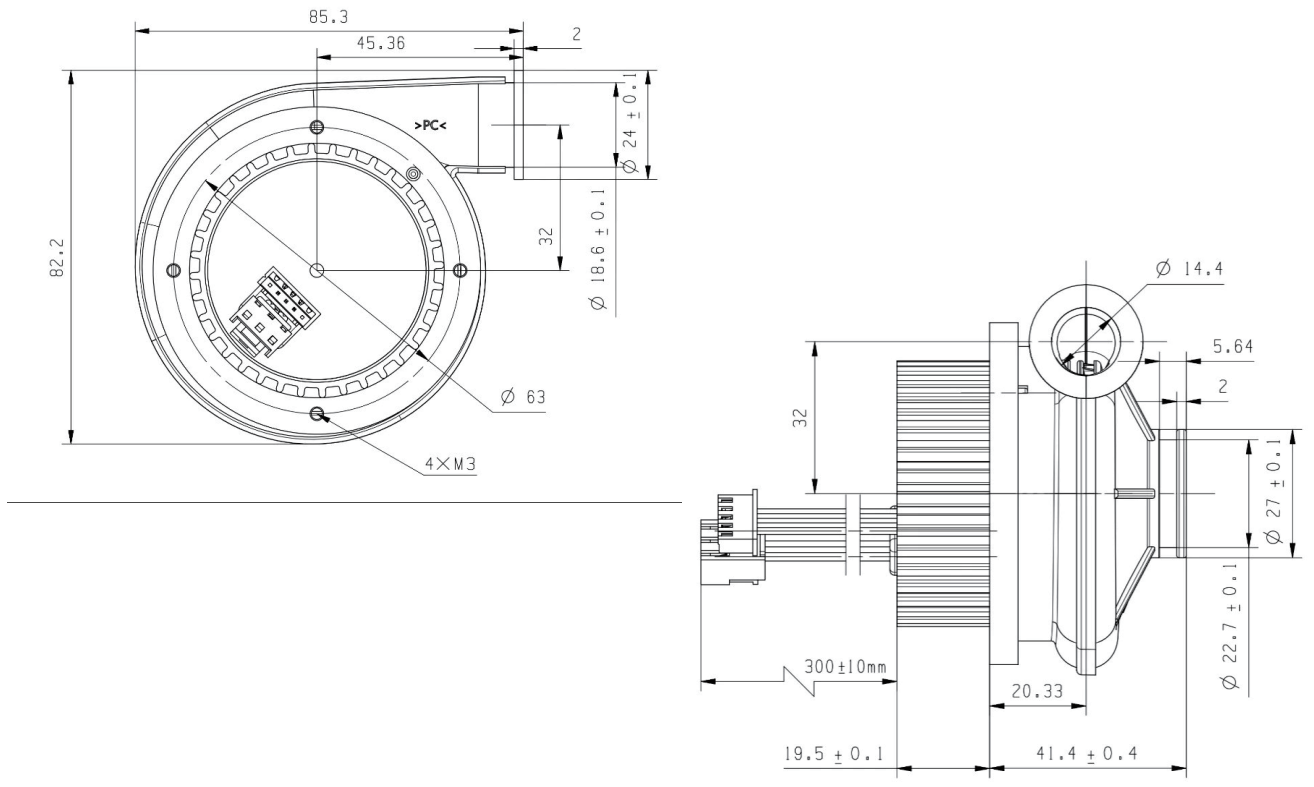

Series Name

C80

Motor Simplified Name

C8003



PRODUCT PARAMETERS

Item Name	C8003
Brand Name	ANCFLOW
Model Number	C8003-24V-1
Part Name	Brushless DC Blower
Rated Power (W)	178
Rated Voltage (V)	24
Power Supply Type	DC
Driver Layout	External
max.Static Pressure	16.0kPa
max.Flow Rate	960LPM (57.6m ³ /h)
Rated Static Pressure	12.0kPa
Rated Flow Rate	453LPM (27.2m ³ /h)
Temperature Range(ambient)	-20°C~+50°C
Humidity Range(ambient)	≤85%RH
Size	85.3*82.2*60.9mm
Service life (L10 at 40)	20,000h
Certification	RoHS, CE, ISO10993
Application Field	medical smoke removal equipment, ventilator, hydrogen fuel cell, cold chain sterilization equipment, disinfection and sterilization equipment, oxygen generator, dental equipment, negative pressure isolation chamber, PARR, moxibustion smoking, household fresh air system, temperature and humidity control, environmental monitoring equipment, gas detector, air cushion aerator, glove box, industrial smoke/dust removal equipment, liquid atomization, cooling and drying equipment, agricultural machinery, fishery aerator, etc.

■ PERFORMANCE CURVES

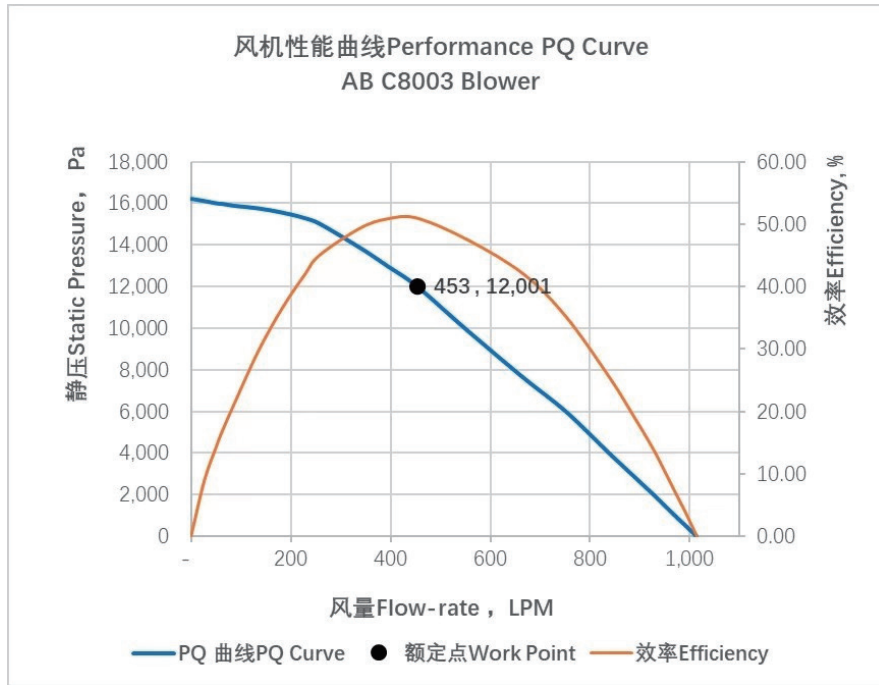

■ INTERFACE DRAWING

C80-1/C80-2 Series

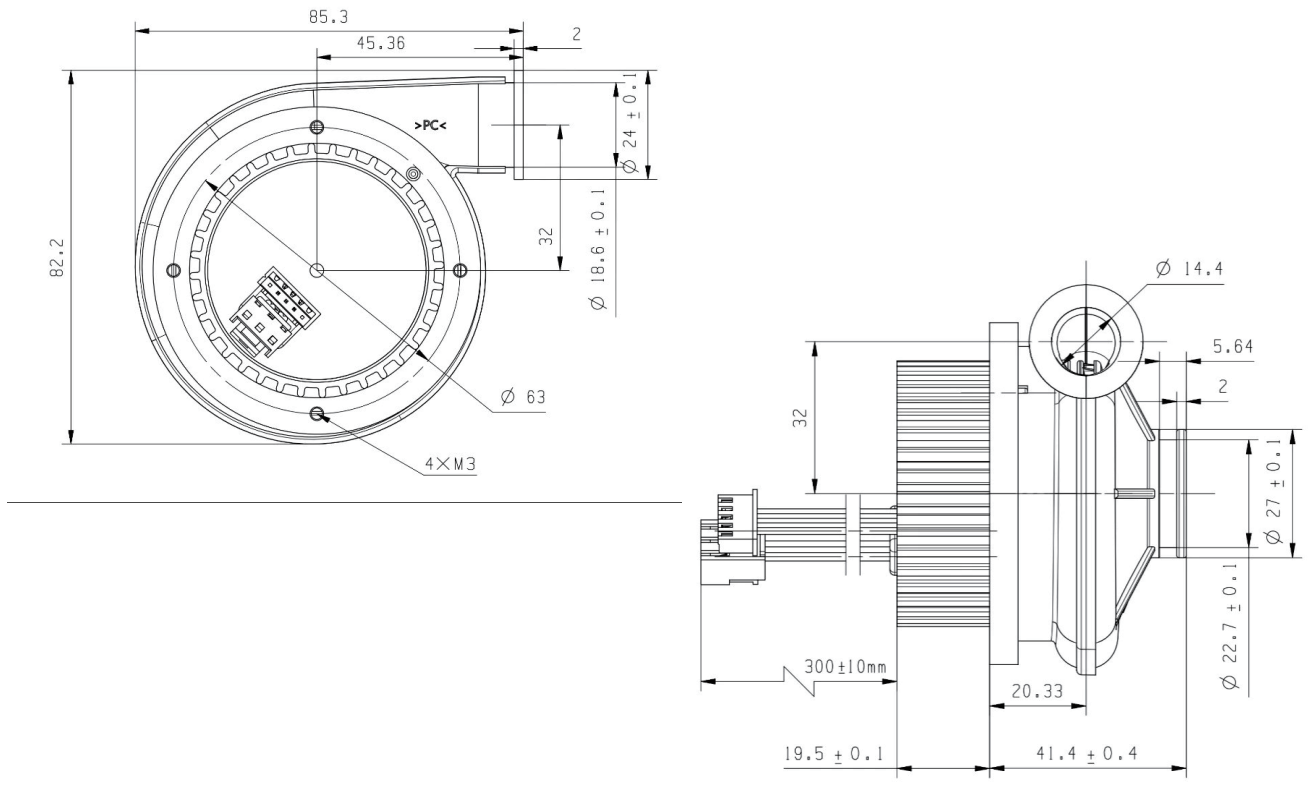

Series Name

C80

Motor Simplified Name

C8004



PRODUCT PARAMETERS

Item Name	C8004
Brand Name	ANCFLOW
Model Number	C8004-24/48V-1
Part Name	Brushless DC Blower
Rated Power (W)	170
Rated Voltage (V)	24/48
Power Supply Type	DC
Driver Layout	External
max.Static Pressure	16.0kPa
max.Flow Rate	960LPM (57.6m ³ /h)
Rated Static Pressure	12.0kPa
Rated Flow Rate	423LPM (25.4m ³ /h)
Temperature Range(ambient)	-20°C~+50°C
Humidity Range(ambient)	≤85%RH
Size	85.3*82.2*60.9mm
Service life (L10 at 40)	20,000h
Certification	RoHS, CE, ISO10993
Application Field	medical smoke removal equipment, ventilator, hydrogen fuel cell, cold chain sterilization equipment, disinfection and sterilization equipment, oxygen generator, dental equipment, negative pressure isolation chamber, PARR, moxibustion smoking, household fresh air system, temperature and humidity control, environmental monitoring equipment, gas detector, air cushion aerator, glove box, industrial smoke/dust removal equipment, liquid atomization, cooling and drying equipment, agricultural machinery, fishery aerator, etc.

■ PERFORMANCE CURVES

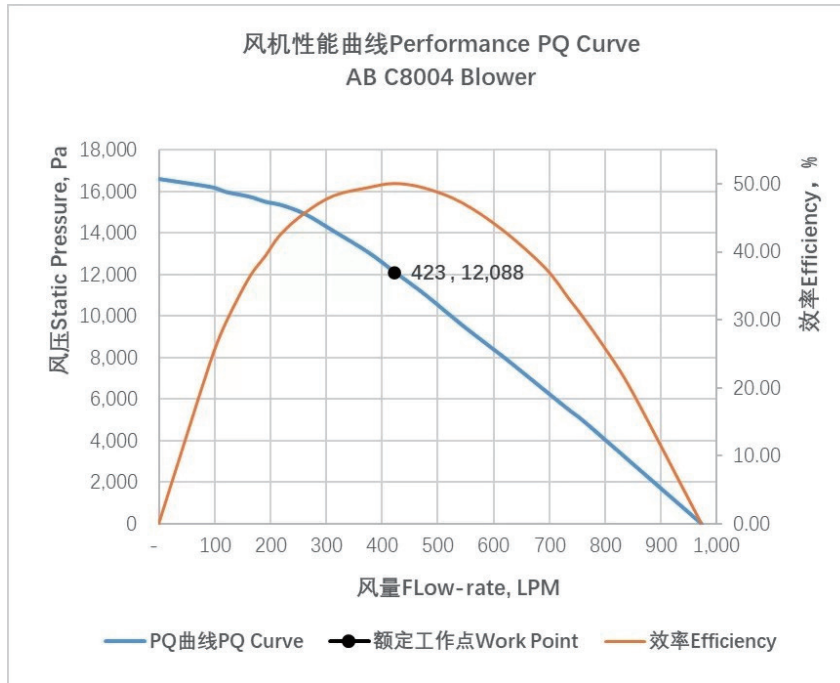

■ INTERFACE DRAWING

C80-1/C80-2 Series

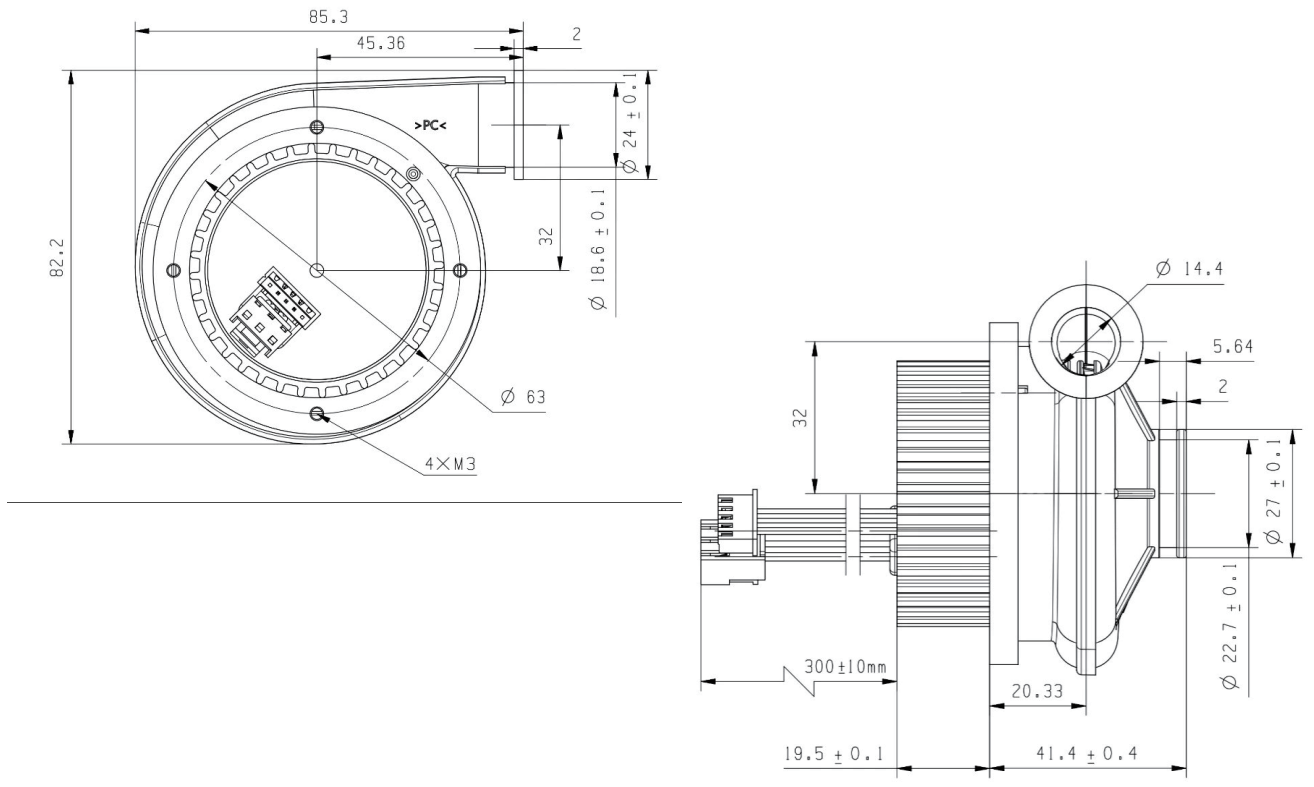

Series Name

C80

Motor Simplified Name

C8005



PRODUCT PARAMETERS

Item Name	C8005
Brand Name	ANCFLOW
Model Number	C8005-24V-1
Part Name	Brushless DC Blower
Rated Power (W)	142
Rated Voltage (V)	24
Power Supply Type	DC
Driver Layout	External
max.Static Pressure	14.5kPa
max.Flow Rate	950LPM (57.0m ³ /h)
Rated Static Pressure	12.0kPa
Rated Flow Rate	363LPM (21.8m ³ /h)
Temperature Range(ambient)	-20°C~+50°C
Humidity Range(ambient)	≤85%RH
Size	85.3*82.2*60.9mm
Service life (L10 at 40)	20,000h
Certification	RoHS, CE, ISO10993
Application Field	medical smoke removal equipment, ventilator, hydrogen fuel cell, cold chain sterilization equipment, disinfection and sterilization equipment, oxygen generator, dental equipment, negative pressure isolation chamber, PARR, moxibustion smoking, household fresh air system, temperature and humidity control, environmental monitoring equipment, gas detector, air cushion aerator, glove box, industrial smoke/dust removal equipment, liquid atomization, cooling and drying equipment, agricultural machinery, fishery aerator, etc.

■ PERFORMANCE CURVES

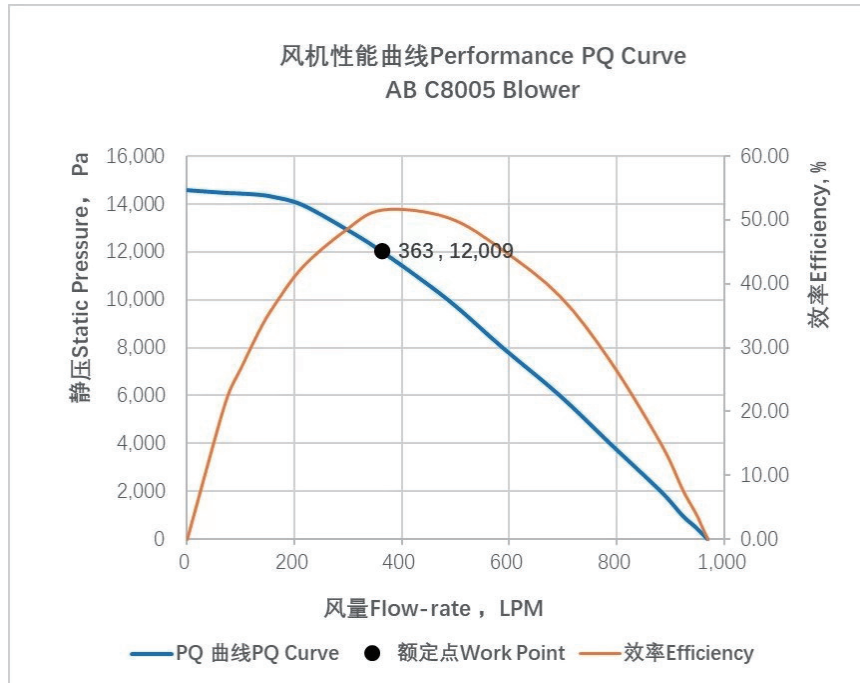

■ INTERFACE DRAWING

C80-1/C80-2 Series

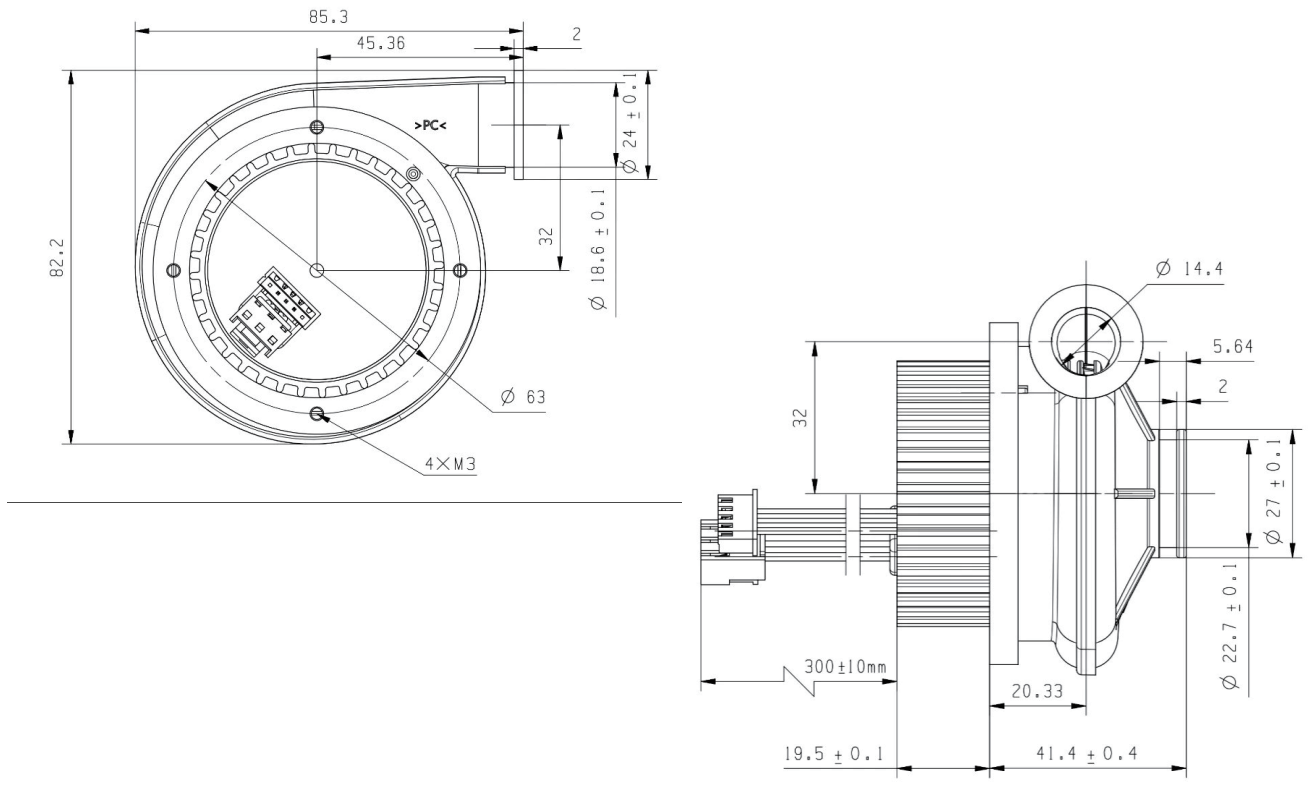

Series Name

C80

Motor Simplified Name

C8006



PRODUCT PARAMETERS

Item Name	C8006
Brand Name	ANCFLOW
Model Number	C8006-24/48V-1
Part Name	Brushless DC Blower
Rated Power (W)	140
Rated Voltage (V)	24/48
Power Supply Type	DC
Driver Layout	External
max.Static Pressure	14.5kPa
max.Flow Rate	910LPM (54.6m ³ /h)
Rated Static Pressure	11.5kPa
Rated Flow Rate	372LPM (22.3m ³ /h)
Temperature Range(ambient)	-20°C~+50°C
Humidity Range(ambient)	≤85%RH
Size	85.3*82.2*60.9mm
Service life (L10 at 40)	20,000h
Certification	RoHS, CE, ISO10993
Application Field	medical smoke removal equipment, ventilator, hydrogen fuel cell, cold chain sterilization equipment, disinfection and sterilization equipment, oxygen generator, dental equipment, negative pressure isolation chamber, PARR, moxibustion smoking, household fresh air system, temperature and humidity control, environmental monitoring equipment, gas detector, air cushion aerator, glove box, industrial smoke/dust removal equipment, liquid atomization, cooling and drying equipment, agricultural machinery, fishery aerator, etc.

■ PERFORMANCE CURVES

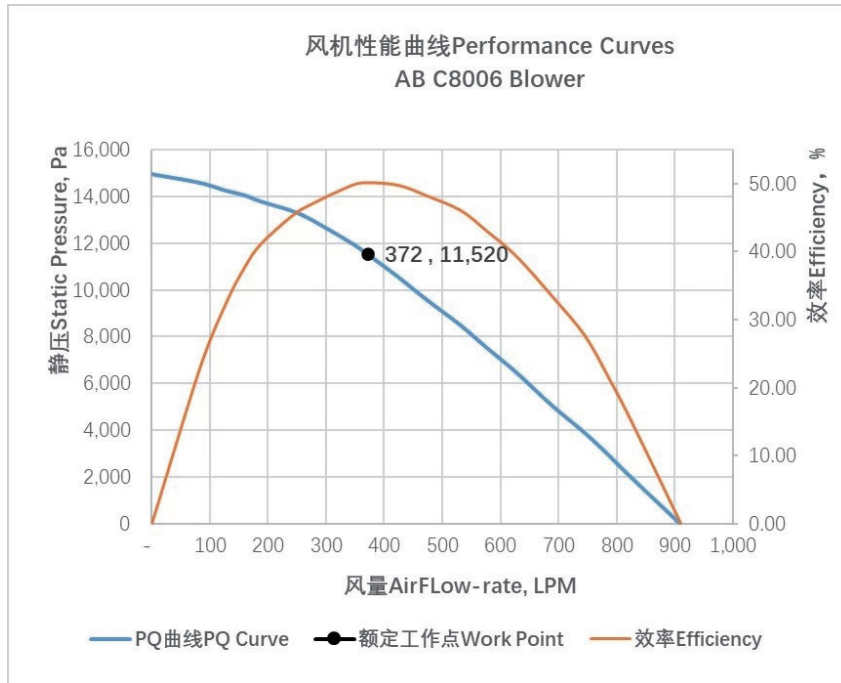

■ INTERFACE DRAWING

C80-1/C80-2 Series

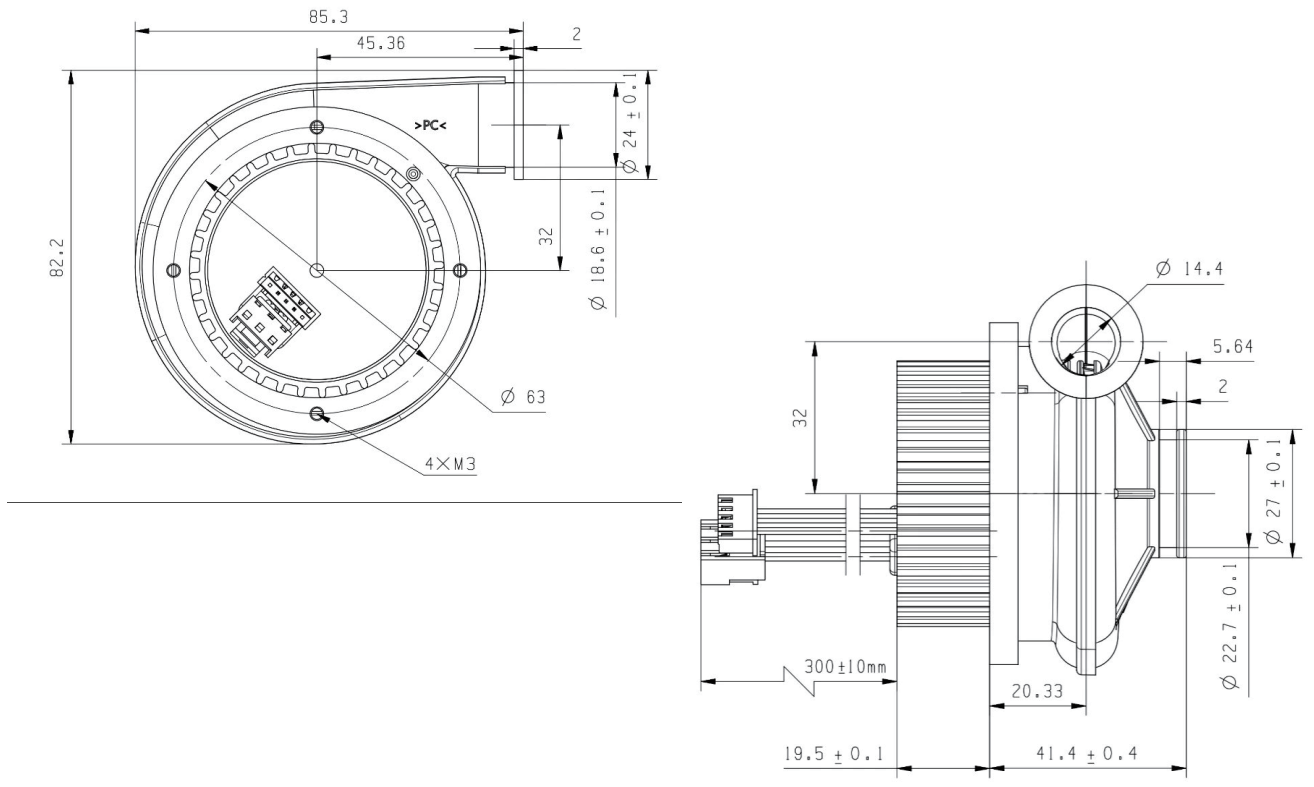

Series Name

C80

Motor Simplified Name

C8007



PRODUCT PARAMETERS

Item Name	C8007
Brand Name	ANCFLOW
Model Number	C8007-24V-1
Part Name	Brushless DC Blower
Rated Power (W)	130
Rated Voltage (V)	24
Power Supply Type	DC
Driver Layout	External
max.Static Pressure	13.5kPa
max.Flow Rate	920LPM (55.2m ³ /h)
Rated Static Pressure	10.0kPa
Rated Flow Rate	405LPM (24.3m ³ /h)
Temperature Range(ambient)	-20°C~+50°C
Humidity Range(ambient)	≤85%RH
Size	85.3*82.2*60.9mm
Service life (L10 at 40)	20,000h
Certification	RoHS, CE, ISO10993
Application Field	medical smoke removal equipment, ventilator, hydrogen fuel cell, cold chain sterilization equipment, disinfection and sterilization equipment, oxygen generator, dental equipment, negative pressure isolation chamber, PARR, moxibustion smoking, household fresh air system, temperature and humidity control, environmental monitoring equipment, gas detector, air cushion aerator, glove box, industrial smoke/dust removal equipment, liquid atomization, cooling and drying equipment, agricultural machinery, fishery aerator, etc.

■ PERFORMANCE CURVES

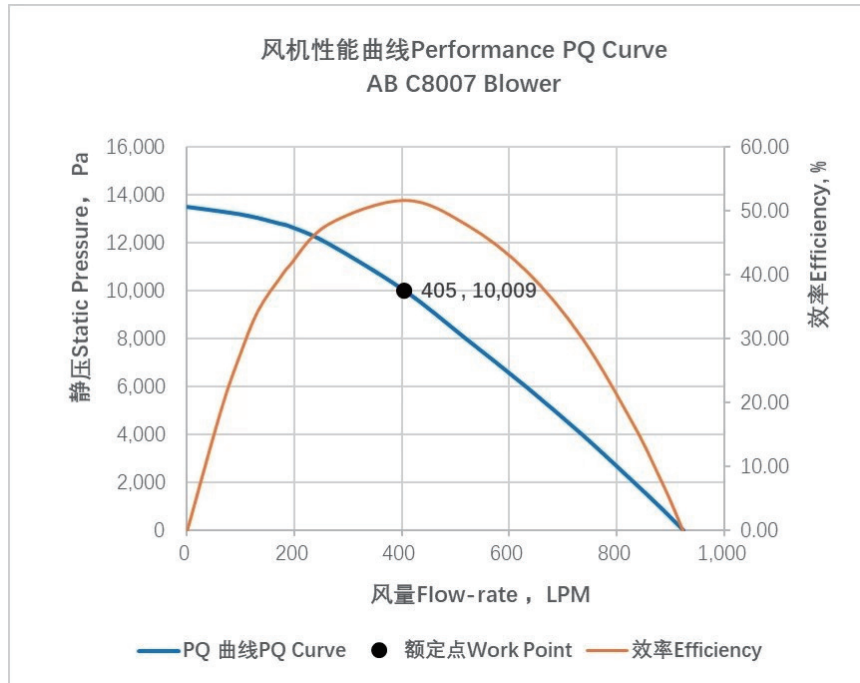

■ INTERFACE DRAWING

C80-1/C80-2 Series

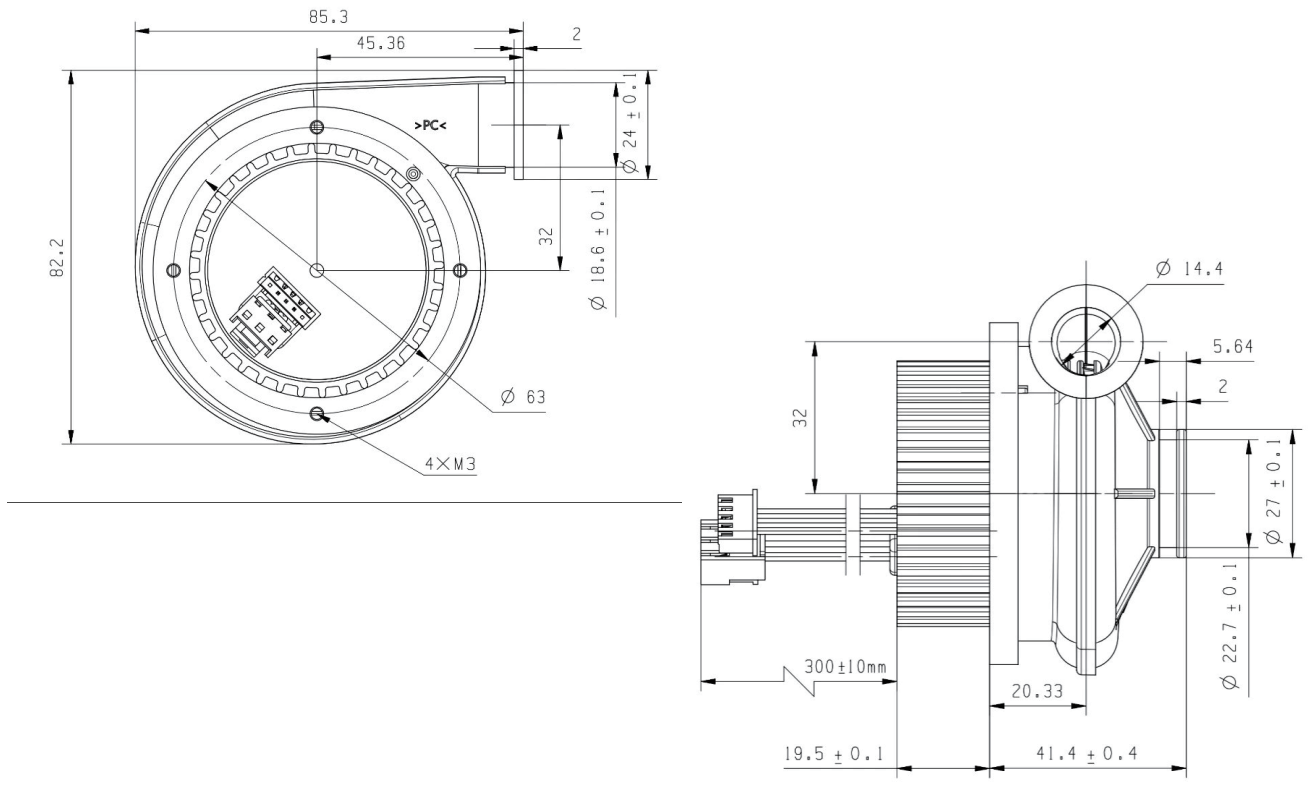

Series Name

C80

Motor Simplified Name

C8008



PRODUCT PARAMETERS

Item Name	C8008
Brand Name	ANCFLOW
Model Number	C8008-24/48V-1
Part Name	Brushless DC Blower
Rated Power (W)	135
Rated Voltage (V)	24/48
Power Supply Type	DC
Driver Layout	External
max.Static Pressure	13.5kPa
max.Flow Rate	887LPM (53.2m ³ /h)
Rated Static Pressure	10.0kPa
Rated Flow Rate	405LPM (24.3m ³ /h)
Temperature Range(ambient)	-20°C~+50°C
Humidity Range(ambient)	≤85%RH
Size	85.3*82.2*60.9mm
Service life (L10 at 40)	20,000h
Certification	RoHS, CE, ISO10993
Application Field	medical smoke removal equipment, ventilator, hydrogen fuel cell, cold chain sterilization equipment, disinfection and sterilization equipment, oxygen generator, dental equipment, negative pressure isolation chamber, PARR, moxibustion smoking, household fresh air system, temperature and humidity control, environmental monitoring equipment, gas detector, air cushion aerator, glove box, industrial smoke/dust removal equipment, liquid atomization, cooling and drying equipment, agricultural machinery, fishery aerator, etc.

■ PERFORMANCE CURVES

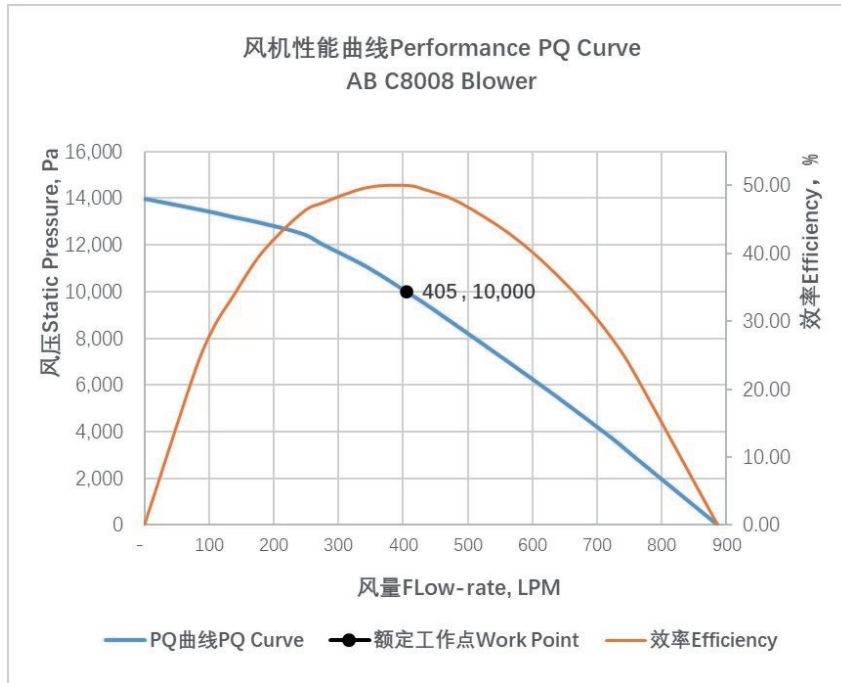

■ INTERFACE DRAWING

C80-1/C80-2 Series

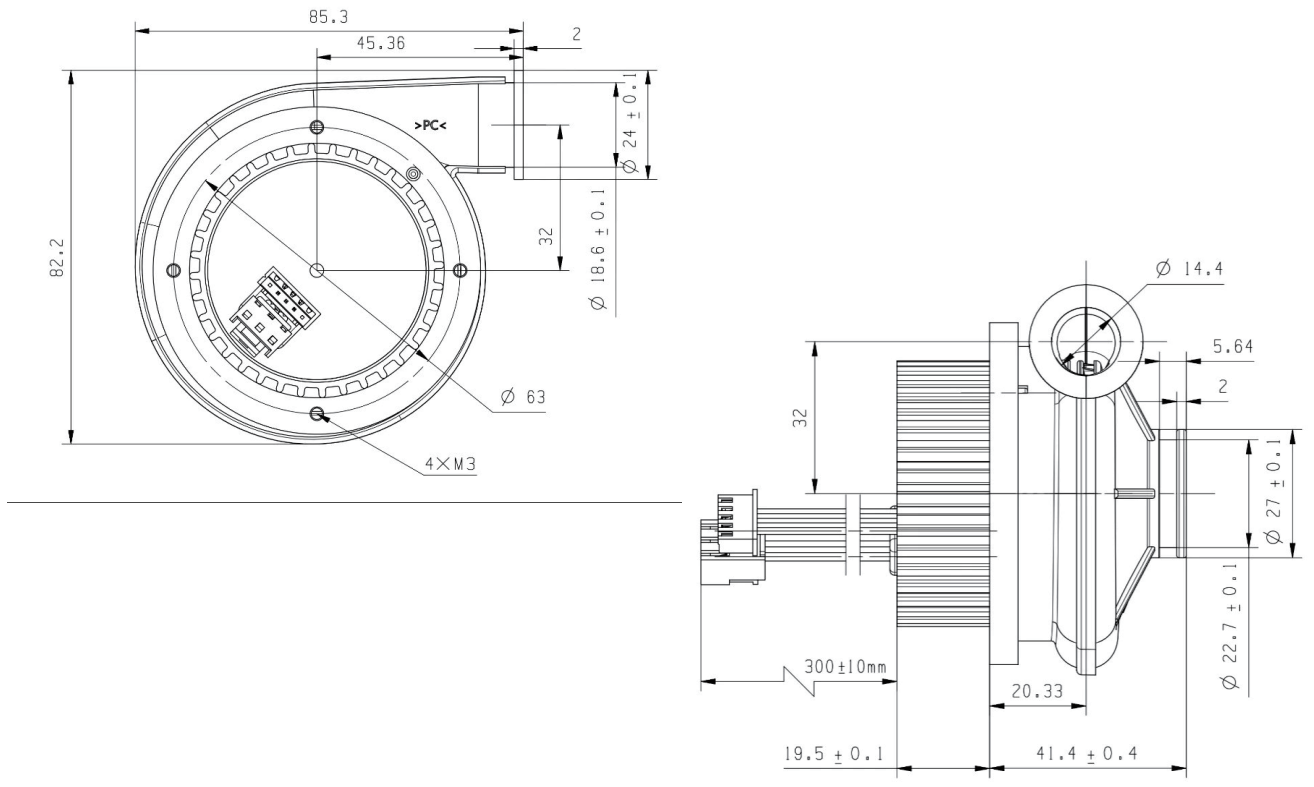

Series Name

C80

Motor Simplified Name

C8009



PRODUCT PARAMETERS

Item Name	C8009
Brand Name	ANCFLOW
Model Number	C8009-24V-1
Part Name	Brushless DC Blower
Rated Power (W)	156
Rated Voltage (V)	24
Power Supply Type	DC
Driver Layout	External
max.Static Pressure	12.0kPa
max.Flow Rate	900LPM (54.0m ³ /h)
Rated Static Pressure	10.0kPa
Rated Flow Rate	353LPM (21.2m ³ /h)
Temperature Range(ambient)	-20°C~+50°C
Humidity Range(ambient)	≤85%RH
Size	85.3*82.2*60.9mm
Service life (L10 at 40)	20,000h
Certification	RoHS, CE, ISO10993
Application Field	medical smoke removal equipment, ventilator, hydrogen fuel cell, cold chain sterilization equipment, disinfection and sterilization equipment, oxygen generator, dental equipment, negative pressure isolation chamber, PARR, moxibustion smoking, household fresh air system, temperature and humidity control, environmental monitoring equipment, gas detector, air cushion aerator, glove box, industrial smoke/dust removal equipment, liquid atomization, cooling and drying equipment, agricultural machinery, fishery aerator, etc.

■ PERFORMANCE CURVES

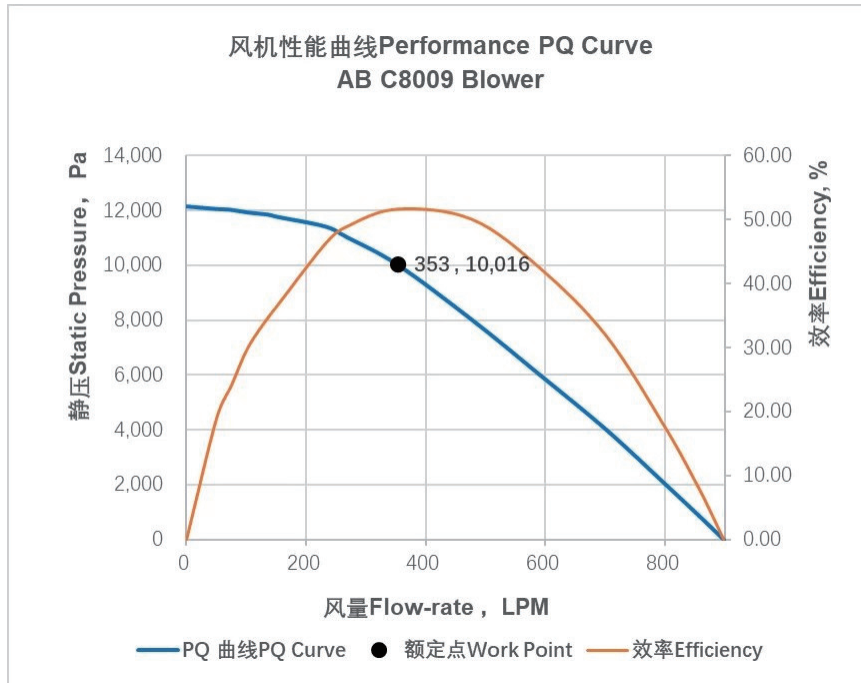

■ INTERFACE DRAWING

C80-1/C80-2 Series

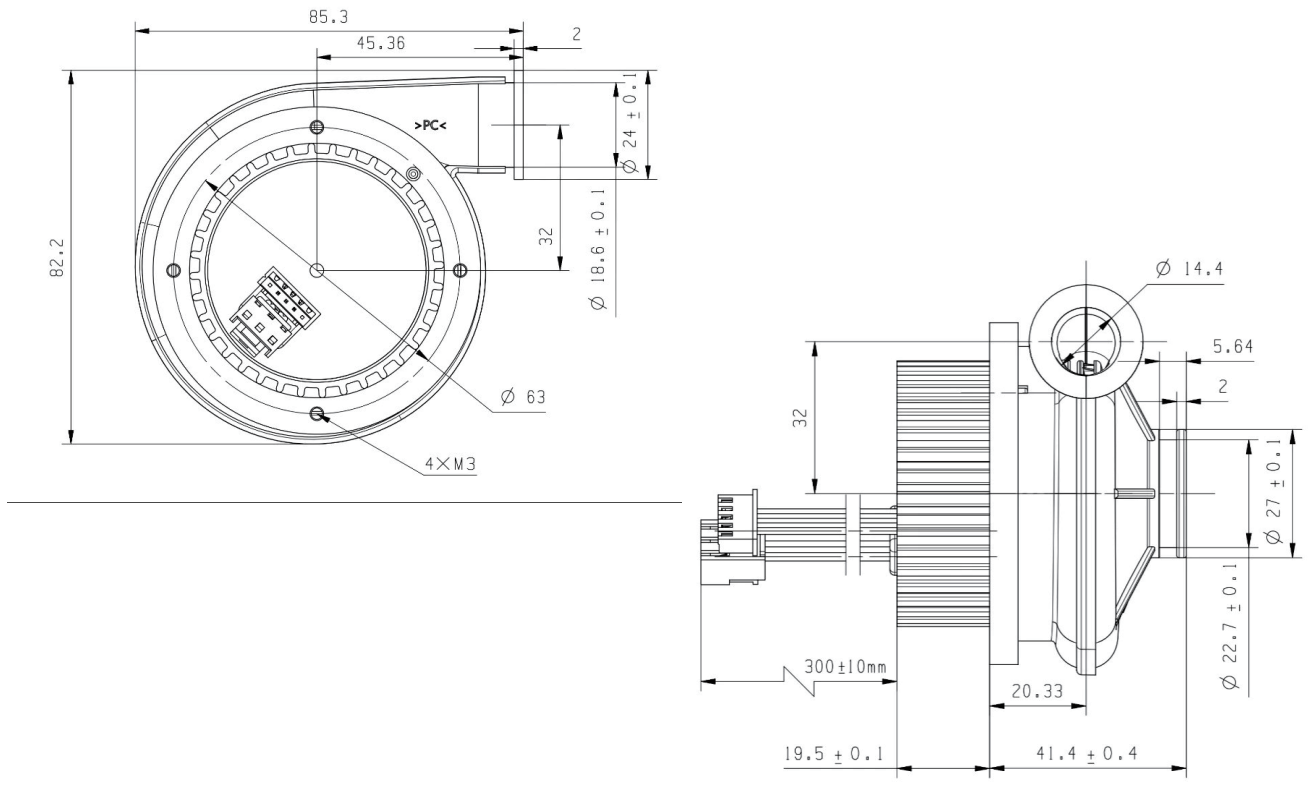

Series Name

C80

Motor Simplified Name

C8010



PRODUCT PARAMETERS

Item Name	C8010
Brand Name	ANCFLOW
Model Number	C8010-24/48V-1
Part Name	Brushless DC Blower
Rated Power (W)	108
Rated Voltage (V)	24/48
Power Supply Type	DC
Driver Layout	External
max.Static Pressure	12.0kPa
max.Flow Rate	832LPM (49.9m ³ /h)
Rated Static Pressure	9.5kPa
Rated Flow Rate	340LPM (20.4m ³ /h)
Temperature Range(ambient)	-20°C~+50°C
Humidity Range(ambient)	≤85%RH
Size	85.3*82.2*60.9mm
Service life (L10 at 40)	20,000h
Certification	RoHS, CE, ISO10993
Application Field	medical smoke removal equipment, ventilator, hydrogen fuel cell, cold chain sterilization equipment, disinfection and sterilization equipment, oxygen generator, dental equipment, negative pressure isolation chamber, PARR, moxibustion smoking, household fresh air system, temperature and humidity control, environmental monitoring equipment, gas detector, air cushion aerator, glove box, industrial smoke/dust removal equipment, liquid atomization, cooling and drying equipment, agricultural machinery, fishery aerator, etc.

■ PERFORMANCE CURVES

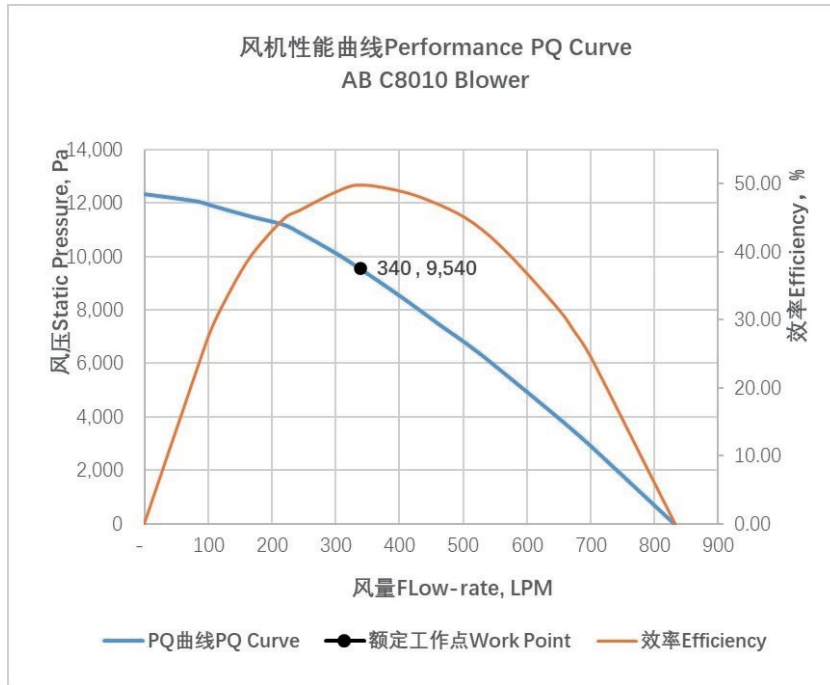

■ INTERFACE DRAWING

C80-1/C80-2 Series

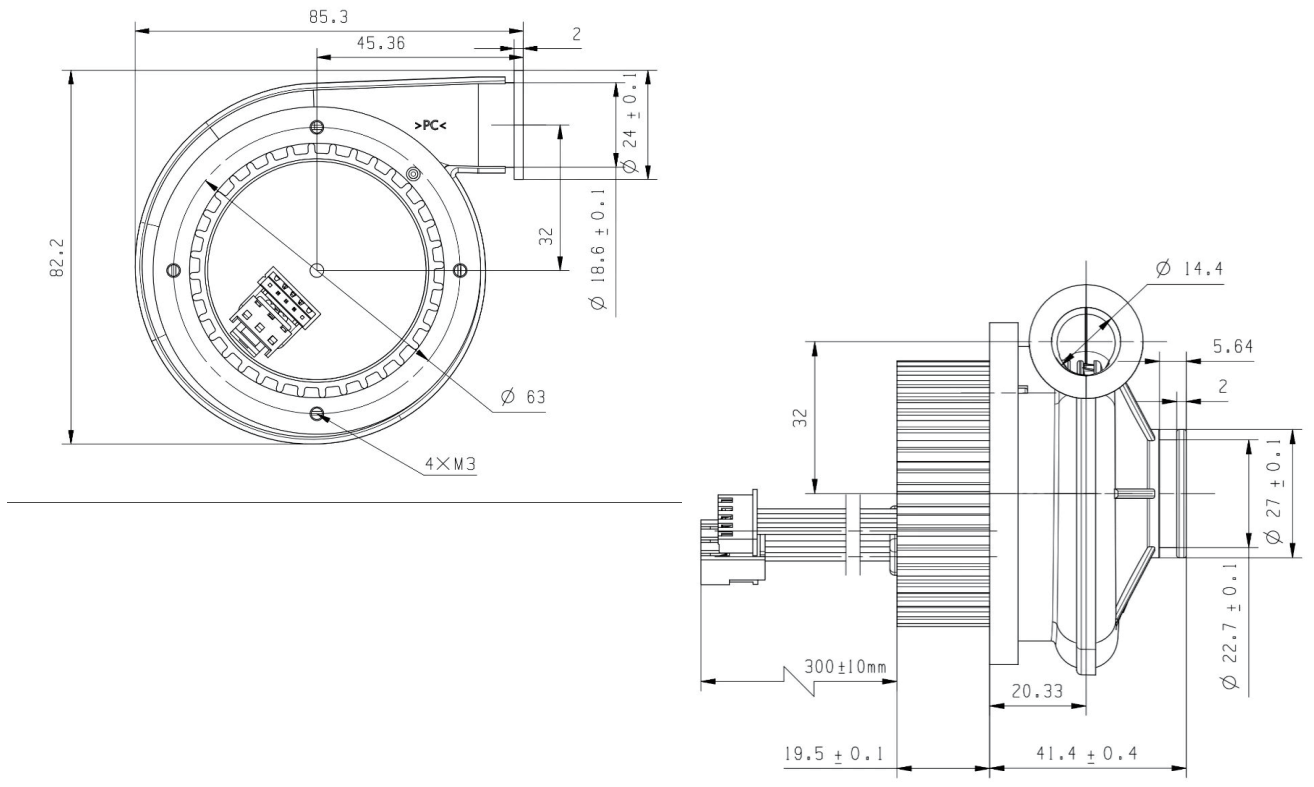

Series Name

C80

Motor Simplified Name

C8011



PRODUCT PARAMETERS

Item Name	C8011
Brand Name	ANCFLOW
Model Number	C8011-24V-1
Part Name	Brushless DC Blower
Rated Power (W)	99
Rated Voltage (V)	24
Power Supply Type	DC
Driver Layout	External
max.Static Pressure	11.0kPa
max.Flow Rate	860LPM (51.6m ³ /h)
Rated Static Pressure	8.0kPa
Rated Flow Rate	425LPM (25.5m ³ /h)
Temperature Range(ambient)	-20°C~+50°C
Humidity Range(ambient)	≤85%RH
Size	85.3*82.2*60.9mm
Service life (L10 at 40)	20,000h
Certification	RoHS, CE, ISO10993
Application Field	medical smoke removal equipment, ventilator, hydrogen fuel cell, cold chain sterilization equipment, disinfection and sterilization equipment, oxygen generator, dental equipment, negative pressure isolation chamber, PARR, moxibustion smoking, household fresh air system, temperature and humidity control, environmental monitoring equipment, gas detector, air cushion aerator, glove box, industrial smoke/dust removal equipment, liquid atomization, cooling and drying equipment, agricultural machinery, fishery aerator, etc.

■ PERFORMANCE CURVES

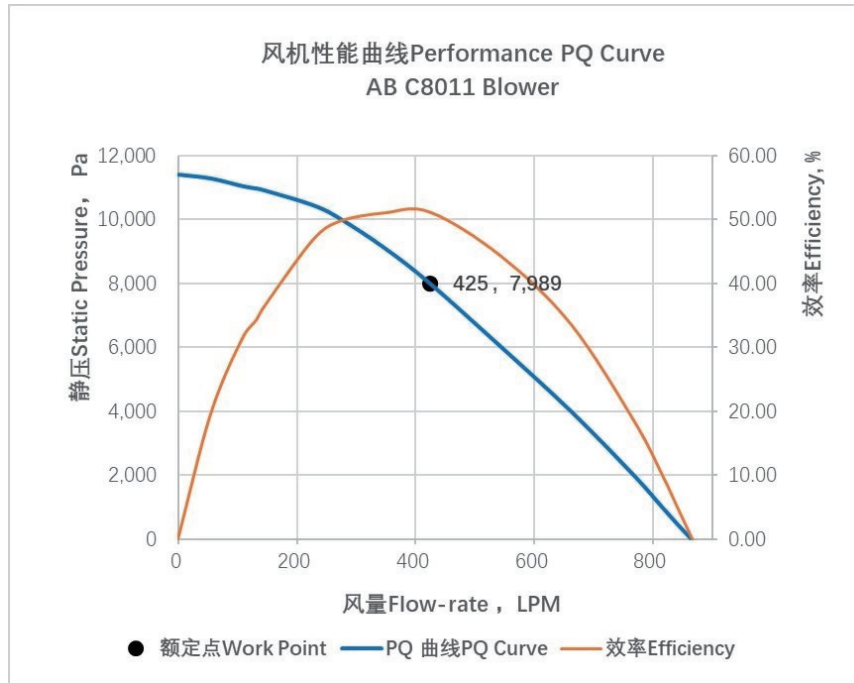

■ INTERFACE DRAWING

C80-1/C80-2 Series

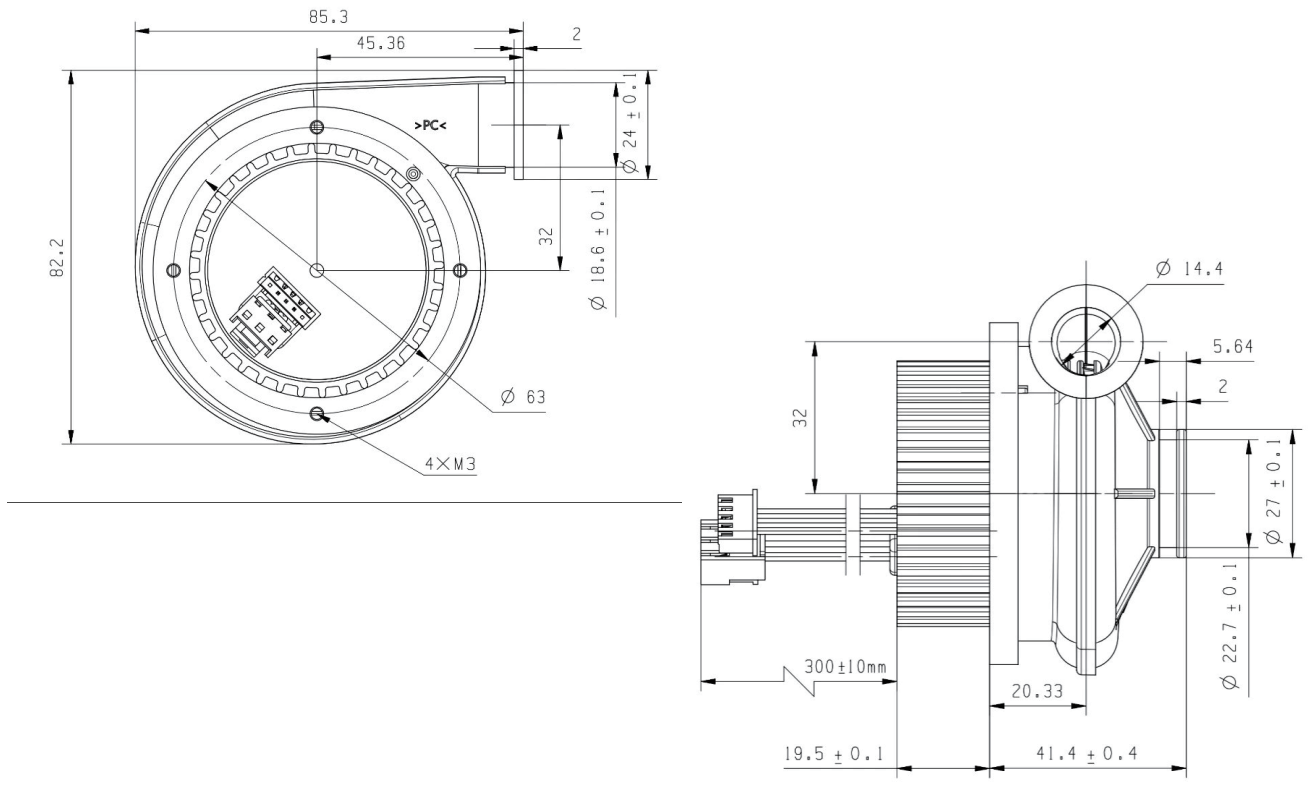

Series Name

C80

Motor Simplified Name

C8012



PRODUCT PARAMETERS

Item Name	C8012
Brand Name	ANCFLOW
Model Number	C8012-12/24/48V-1
Part Name	Brushless DC Blower
Rated Power (W)	96
Rated Voltage (V)	12/24/48
Power Supply Type	DC
Driver Layout	External
max.Static Pressure	11.0kPa
max.Flow Rate	807LPM (48.4m ³ /h)
Rated Static Pressure	9.1kPa
Rated Flow Rate	310LPM (18.6m ³ /h)
Temperature Range(ambient)	-20°C~+50°C
Humidity Range(ambient)	≤85%RH
Size	85.3*82.2*60.9mm
Service life (L10 at 40)	20,000h
Certification	RoHS, CE, ISO10993
Application Field	medical smoke removal equipment, ventilator, hydrogen fuel cell, cold chain sterilization equipment, disinfection and sterilization equipment, oxygen generator, dental equipment, negative pressure isolation chamber, PARR, moxibustion smoking, household fresh air system, temperature and humidity control, environmental monitoring equipment, gas detector, air cushion aerator, glove box, industrial smoke/dust removal equipment, liquid atomization, cooling and drying equipment, agricultural machinery, fishery aerator, etc.

■ PERFORMANCE CURVES

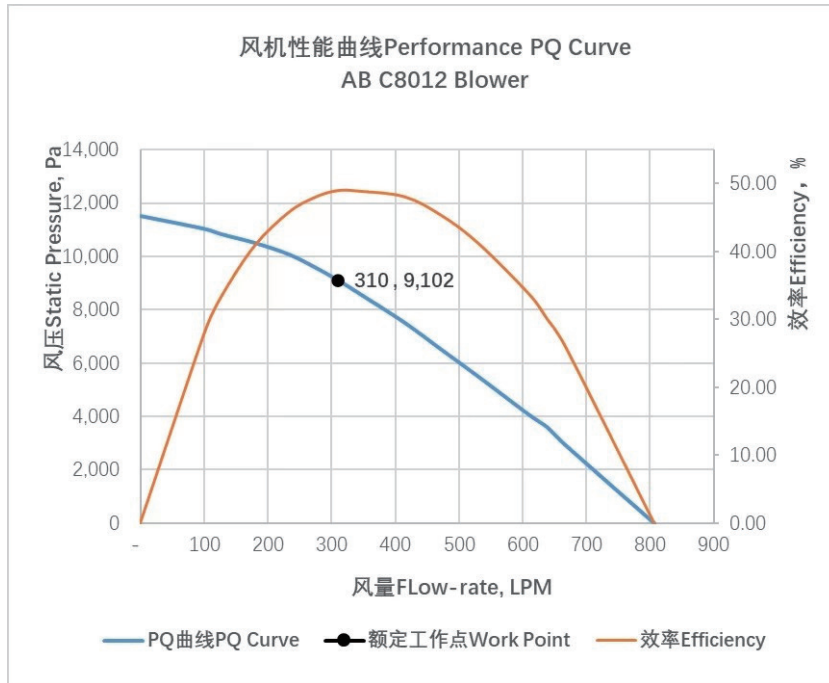

■ INTERFACE DRAWING

C80-1/C80-2 Series

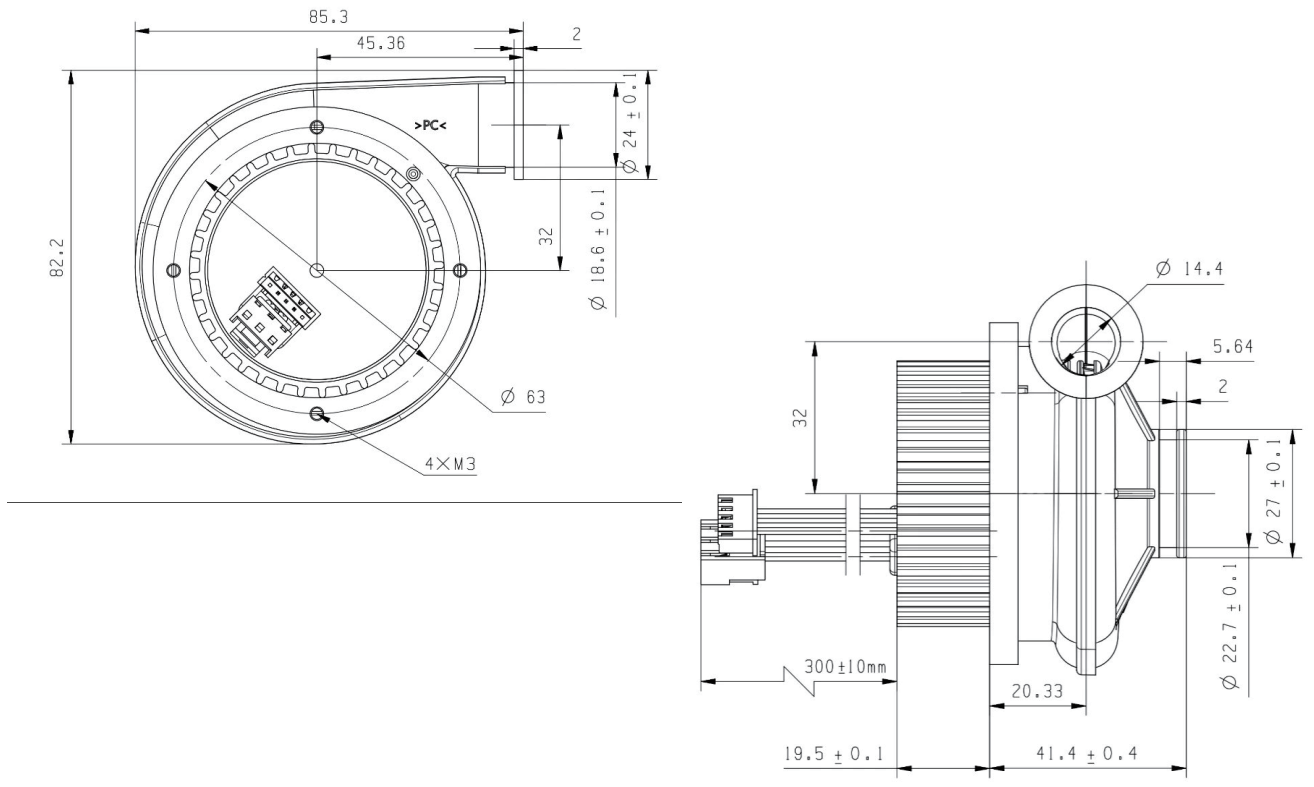

Series Name

C80

Motor Simplified Name

C8013



PRODUCT PARAMETERS

Item Name	C8013
Brand Name	ANCFLOW
Model Number	C8013-24V-1
Part Name	Brushless DC Blower
Rated Power (W)	92
Rated Voltage (V)	24
Power Supply Type	DC
Driver Layout	External
max.Static Pressure	10.0kPa
max.Flow Rate	750LPM (45.0m ³ /h)
Rated Static Pressure	7.1kPa
Rated Flow Rate	368LPM (22.1m ³ /h)
Temperature Range(ambient)	-20°C~+50°C
Humidity Range(ambient)	≤85%RH
Size	85.3*82.2*60.9mm
Service life (L10 at 40)	20,000h
Certification	RoHS, CE, ISO10993
Application Field	medical smoke removal equipment, ventilator, hydrogen fuel cell, cold chain sterilization equipment, disinfection and sterilization equipment, oxygen generator, dental equipment, negative pressure isolation chamber, PARR, moxibustion smoking, household fresh air system, temperature and humidity control, environmental monitoring equipment, gas detector, air cushion aerator, glove box, industrial smoke/dust removal equipment, liquid atomization, cooling and drying equipment, agricultural machinery, fishery aerator, etc.

■ PERFORMANCE CURVES

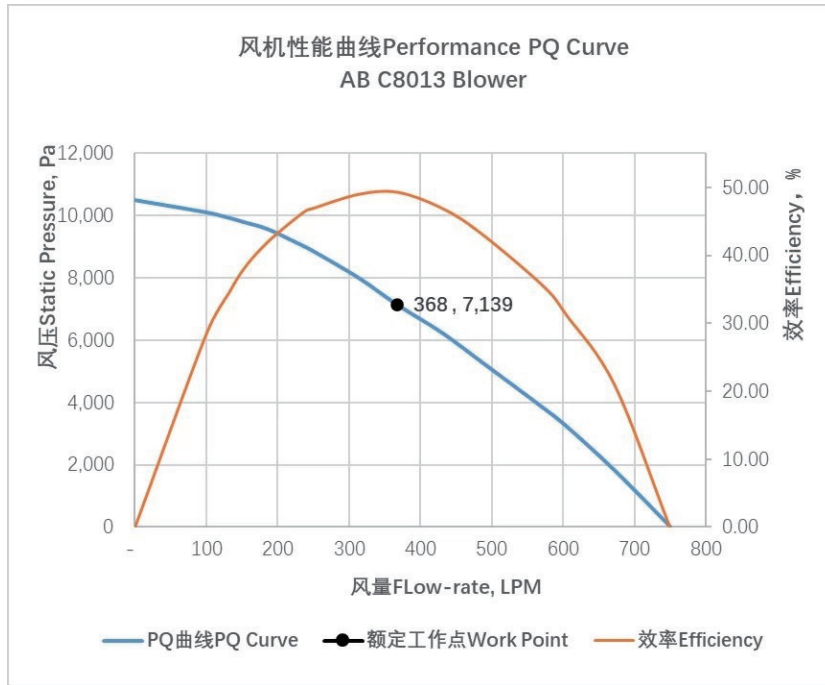

■ INTERFACE DRAWING

C80-1/C80-2 Series

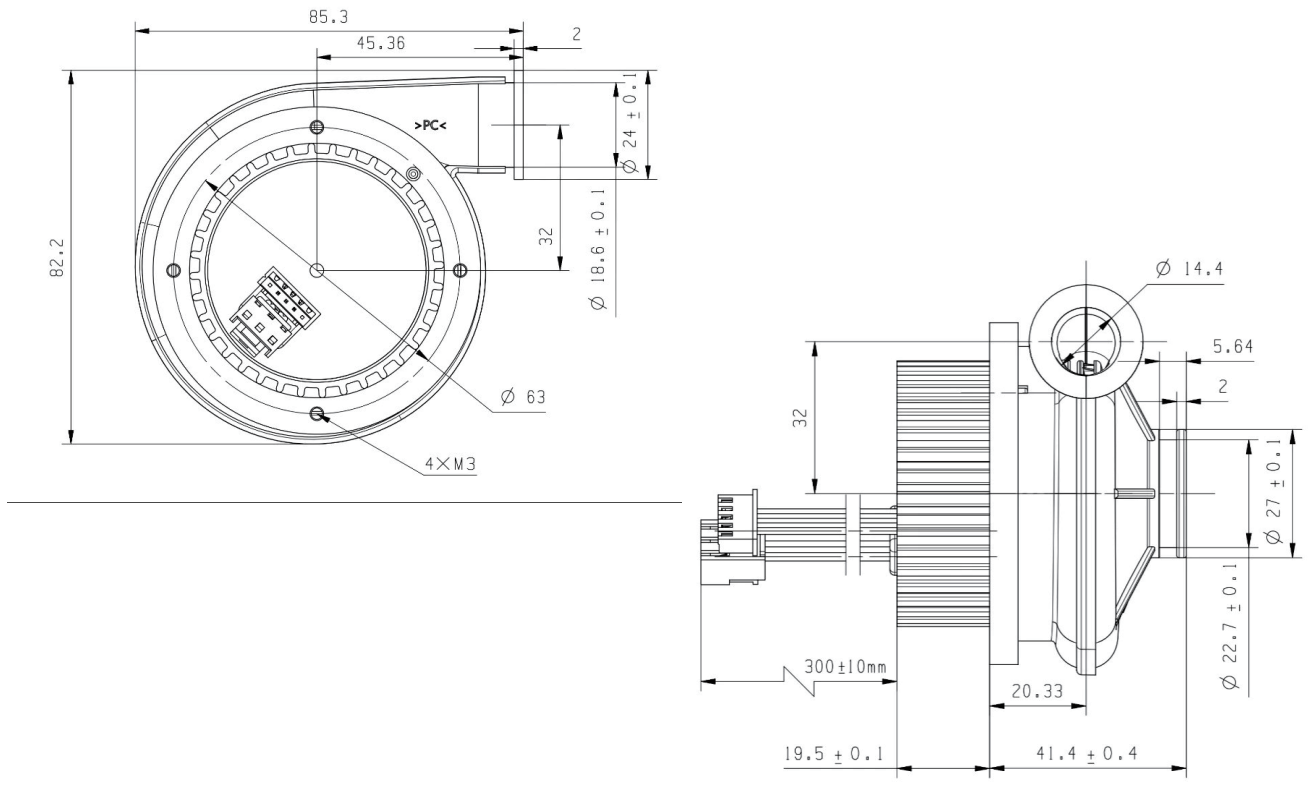

Series Name

C80

Motor Simplified Name

C8014



PRODUCT PARAMETERS

Item Name	C8014
Brand Name	ANCFLOW
Model Number	C8014-12/24/48V-1
Part Name	Brushless DC Blower
Rated Power (W)	90
Rated Voltage (V)	12/24/48
Power Supply Type	DC
Driver Layout	External
max.Static Pressure	10.0kPa
max.Flow Rate	777LPM (46.6m ³ /h)
Rated Static Pressure	7.4kPa
Rated Flow Rate	355LPM (21.3m ³ /h)
Temperature Range(ambient)	-20°C~+50°C
Humidity Range(ambient)	≤85%RH
Size	85.3*82.2*60.9mm
Service life (L10 at 40)	20,000h
Certification	RoHS, CE, ISO10993
Application Field	medical smoke removal equipment, ventilator, hydrogen fuel cell, cold chain sterilization equipment, disinfection and sterilization equipment, oxygen generator, dental equipment, negative pressure isolation chamber, PARR, moxibustion smoking, household fresh air system, temperature and humidity control, environmental monitoring equipment, gas detector, air cushion aerator, glove box, industrial smoke/dust removal equipment, liquid atomization, cooling and drying equipment, agricultural machinery, fishery aerator, etc.

■ PERFORMANCE CURVES

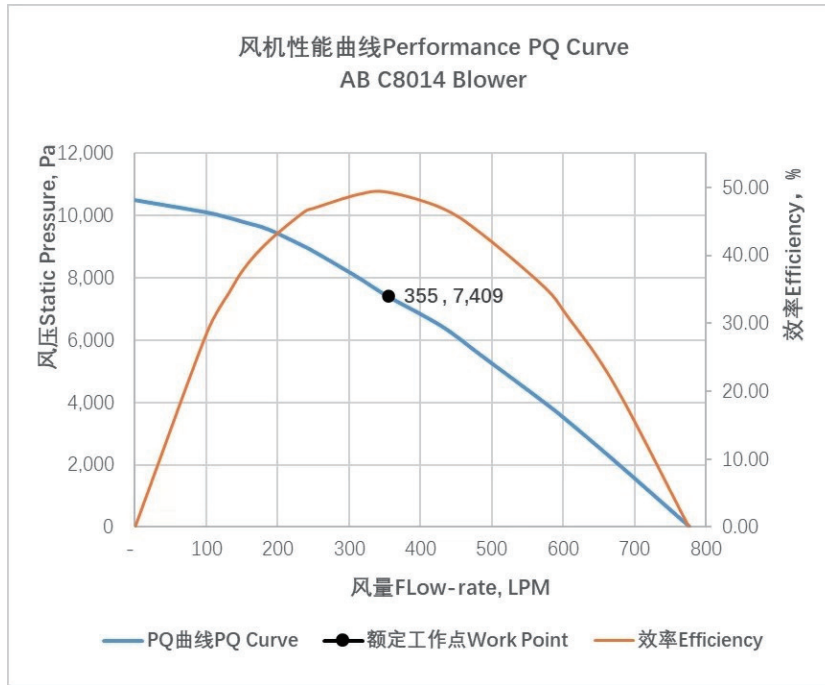

■ INTERFACE DRAWING

C80-1/C80-2 Series

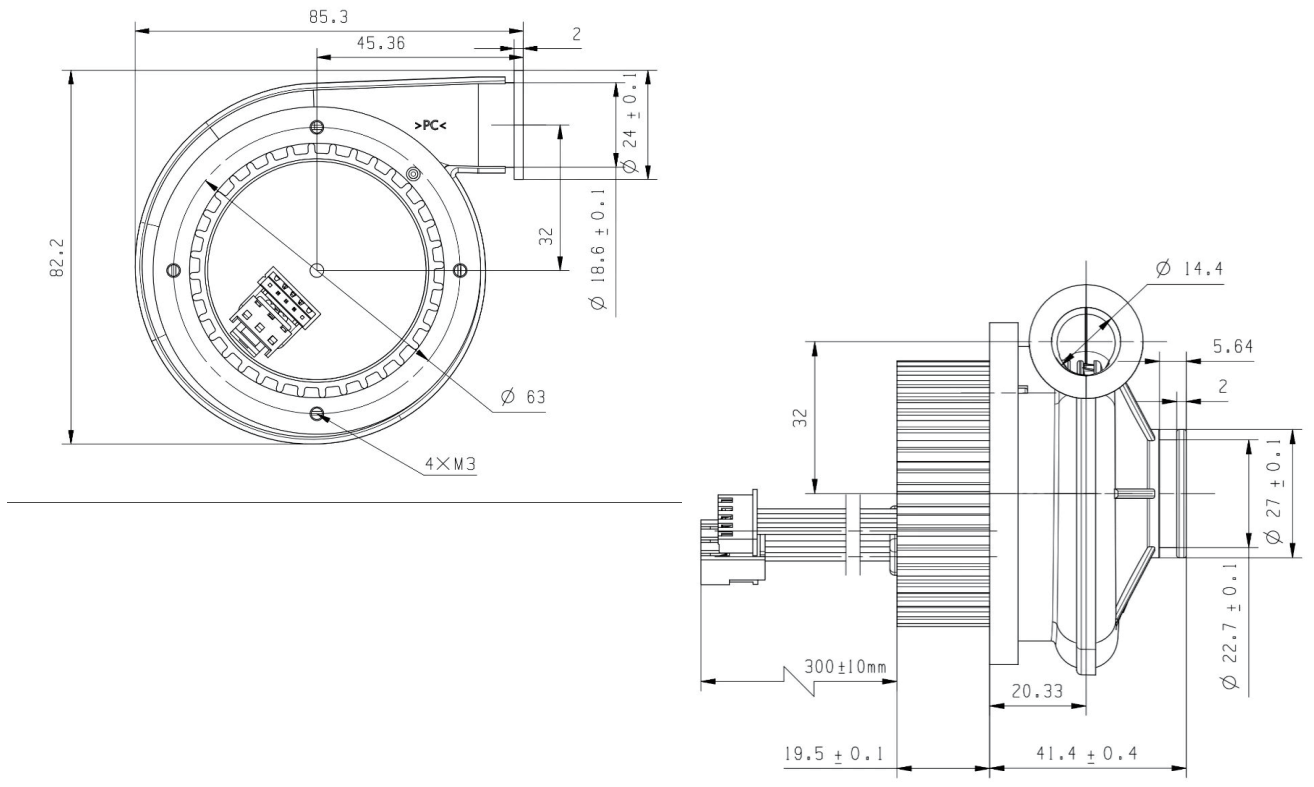

Series Name

C80

Motor Simplified Name

C8015



PRODUCT PARAMETERS

Item Name	C8015
Brand Name	ANCFLOW
Model Number	C8015-24V-1
Part Name	Brushless DC Blower
Rated Power (W)	72
Rated Voltage (V)	24
Power Supply Type	DC
Driver Layout	External
max.Static Pressure	8.5kPa
max.Flow Rate	700LPM (42.0m ³ /h)
Rated Static Pressure	6.7kPa
Rated Flow Rate	292LPM (17.5m ³ /h)
Temperature Range(ambient)	-20°C~+50°C
Humidity Range(ambient)	≤85%RH
Size	85.3*82.2*60.9mm
Service life (L10 at 40)	20,000h
Certification	RoHS, CE, ISO10993
Application Field	medical smoke removal equipment, ventilator, hydrogen fuel cell, cold chain sterilization equipment, disinfection and sterilization equipment, oxygen generator, dental equipment, negative pressure isolation chamber, PARR, moxibustion smoking, household fresh air system, temperature and humidity control, environmental monitoring equipment, gas detector, air cushion aerator, glove box, industrial smoke/dust removal equipment, liquid atomization, cooling and drying equipment, agricultural machinery, fishery aerator, etc.

■ PERFORMANCE CURVES

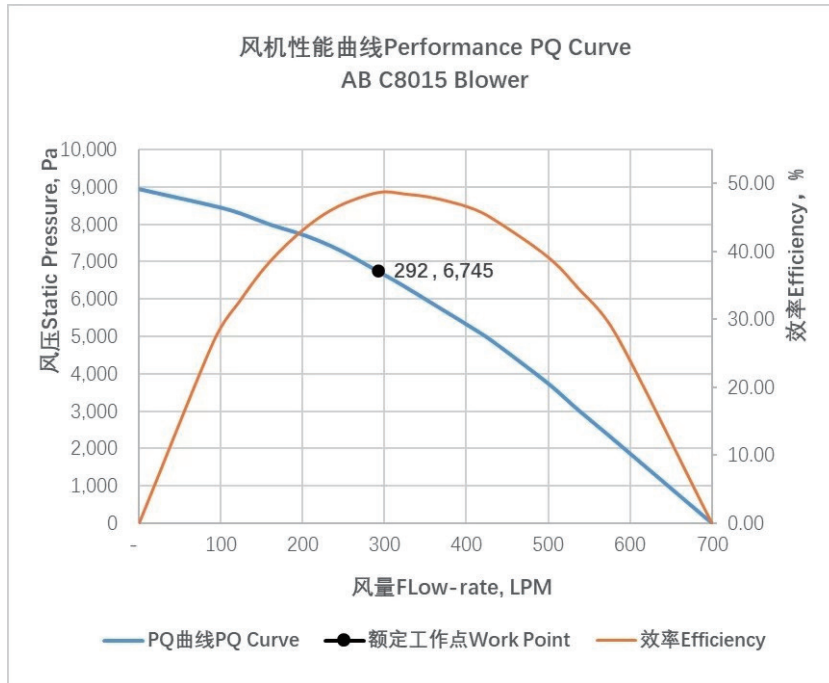

■ INTERFACE DRAWING

C80-1/C80-2 Series

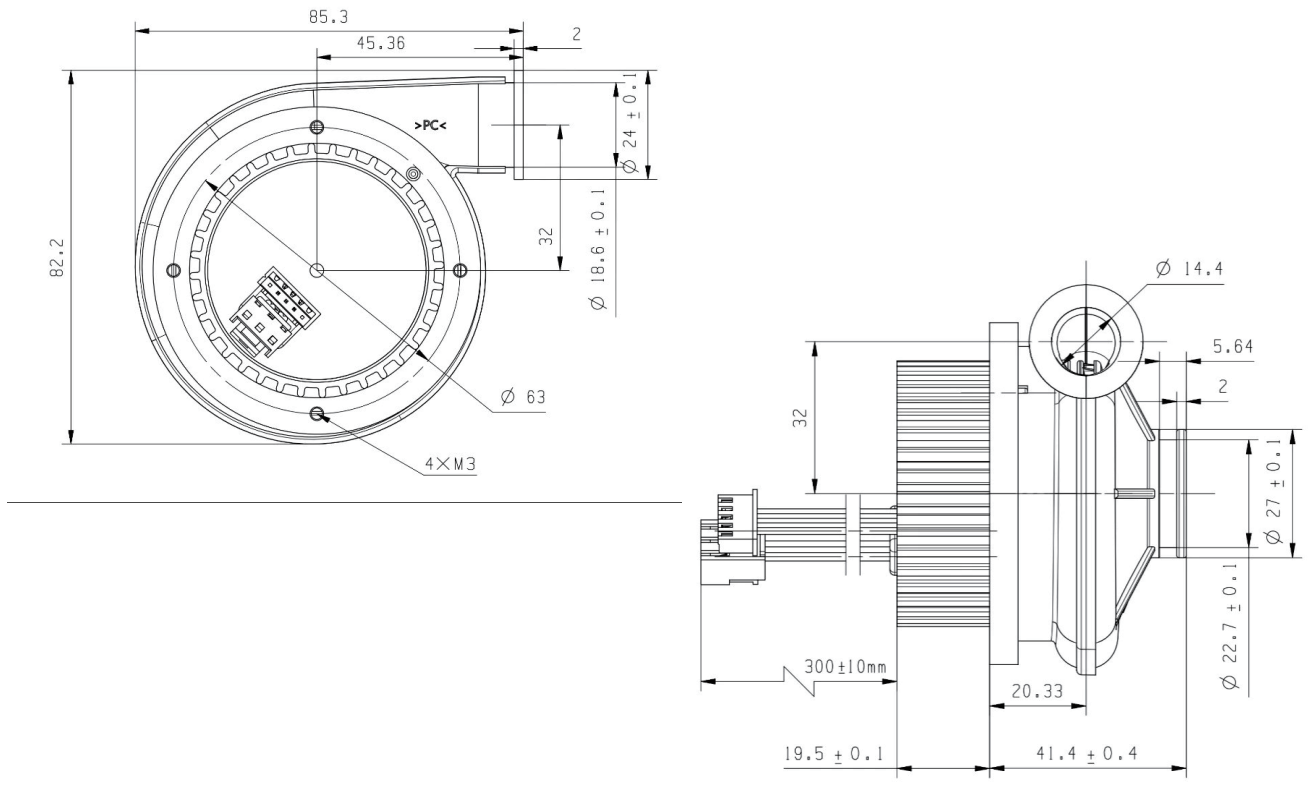

Series Name

C80

Motor Simplified Name

C8016



PRODUCT PARAMETERS

Item Name	C8016
Brand Name	ANCFLOW
Model Number	C8016-12/24/48V-1
Part Name	Brushless DC Blower
Rated Power (W)	70
Rated Voltage (V)	12/24/48
Power Supply Type	DC
Driver Layout	External
max.Static Pressure	8.5kPa
max.Flow Rate	722LPM (43.3m ³ /h)
Rated Static Pressure	7.0kPa
Rated Flow Rate	282LPM (16.9m ³ /h)
Temperature Range(ambient)	-20°C~+50°C
Humidity Range(ambient)	≤85%RH
Size	85.3*82.2*60.9mm
Service life (L10 at 40)	20,000h
Certification	RoHS, CE, ISO10993
Application Field	medical smoke removal equipment, ventilator, hydrogen fuel cell, cold chain sterilization equipment, disinfection and sterilization equipment, oxygen generator, dental equipment, negative pressure isolation chamber, PARR, moxibustion smoking, household fresh air system, temperature and humidity control, environmental monitoring equipment, gas detector, air cushion aerator, glove box, industrial smoke/dust removal equipment, liquid atomization, cooling and drying equipment, agricultural machinery, fishery aerator, etc.

■ PERFORMANCE CURVES

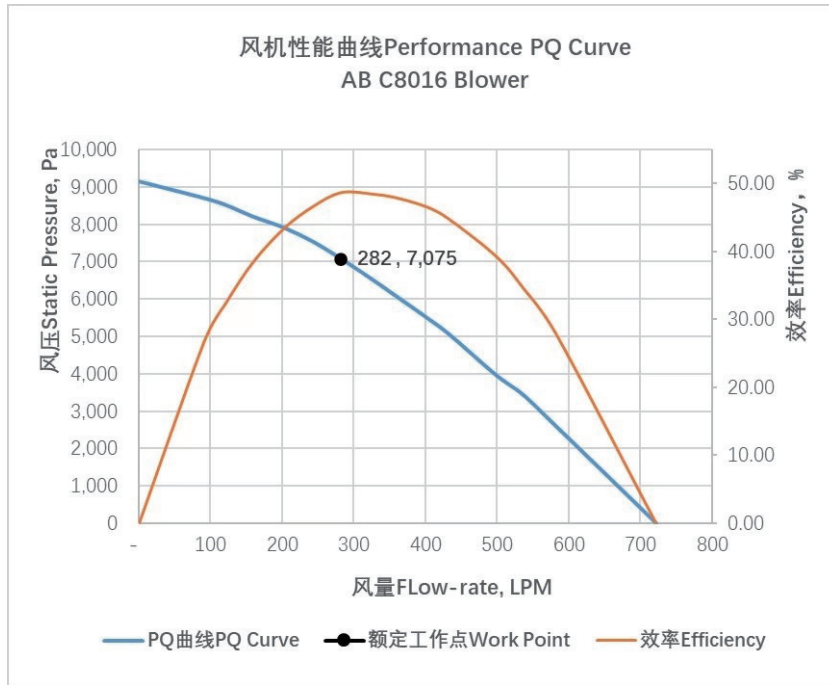

■ INTERFACE DRAWING

C80-1/C80-2 Series

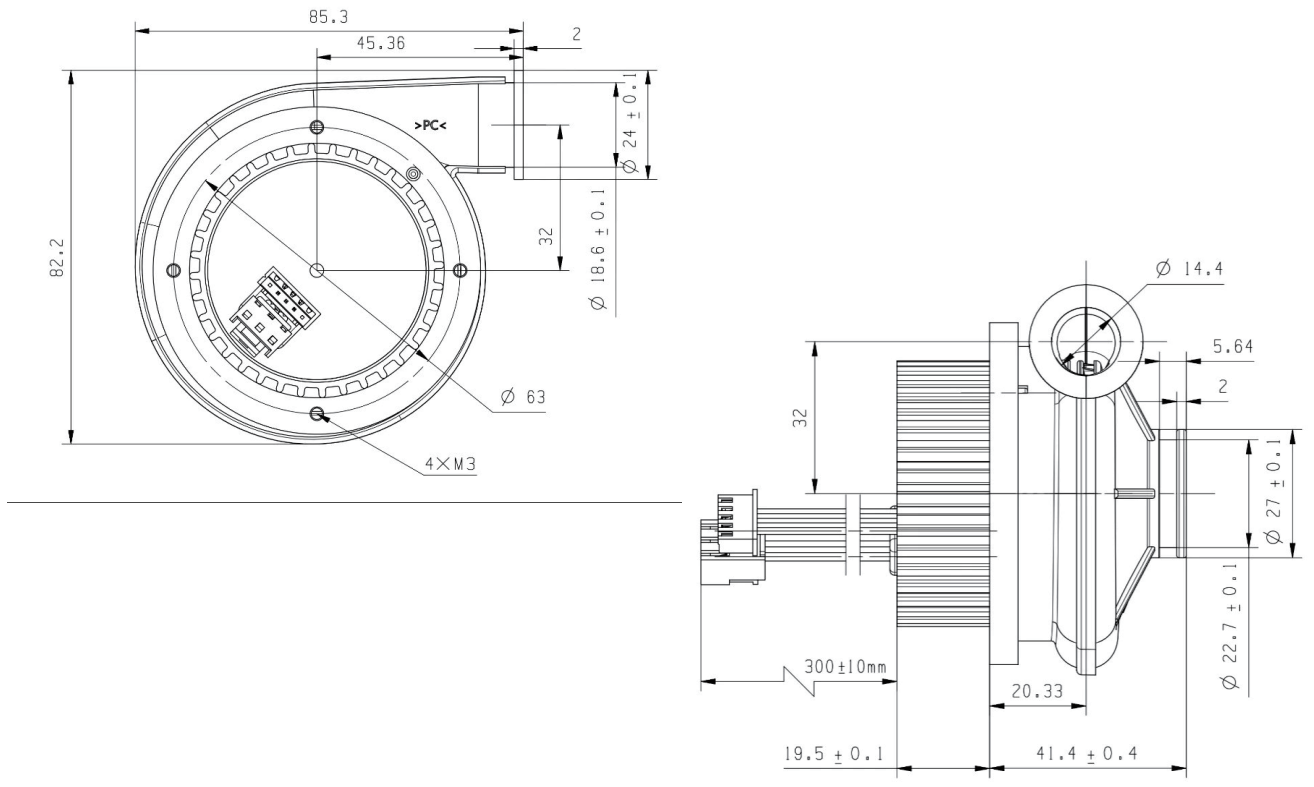

Series Name

C80

Motor Simplified Name

C8017



PRODUCT PARAMETERS

Item Name	C8017
Brand Name	ANCFLOW
Model Number	C8017-24V-1
Part Name	Brushless DC Blower
Rated Power (W)	62
Rated Voltage (V)	24
Power Supply Type	DC
Driver Layout	External
max.Static Pressure	7.5kPa
max.Flow Rate	650LPM (39.0m ³ /h)
Rated Static Pressure	5.2kPa
Rated Flow Rate	310LPM (18.6m ³ /h)
Temperature Range(ambient)	-20°C~+50°C
Humidity Range(ambient)	≤85%RH
Size	85.3*82.2*60.9mm
Service life (L10 at 40)	20,000h
Certification	RoHS, CE, ISO10993
Application Field	medical smoke removal equipment, ventilator, hydrogen fuel cell, cold chain sterilization equipment, disinfection and sterilization equipment, oxygen generator, dental equipment, negative pressure isolation chamber, PARR, moxibustion smoking, household fresh air system, temperature and humidity control, environmental monitoring equipment, gas detector, air cushion aerator, glove box, industrial smoke/dust removal equipment, liquid atomization, cooling and drying equipment, agricultural machinery, fishery aerator, etc.

■ PERFORMANCE CURVES

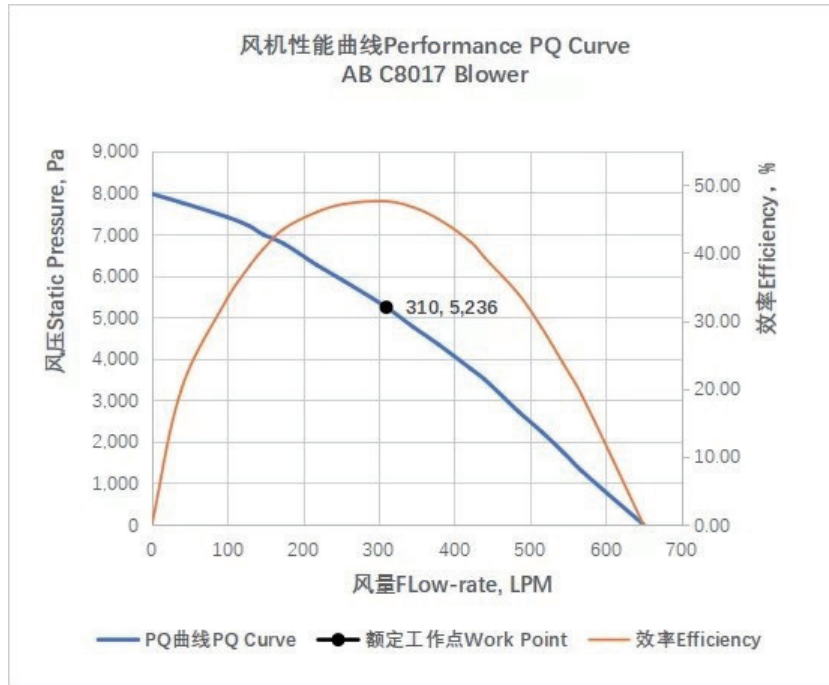

■ INTERFACE DRAWING

C80-1/C80-2 Series

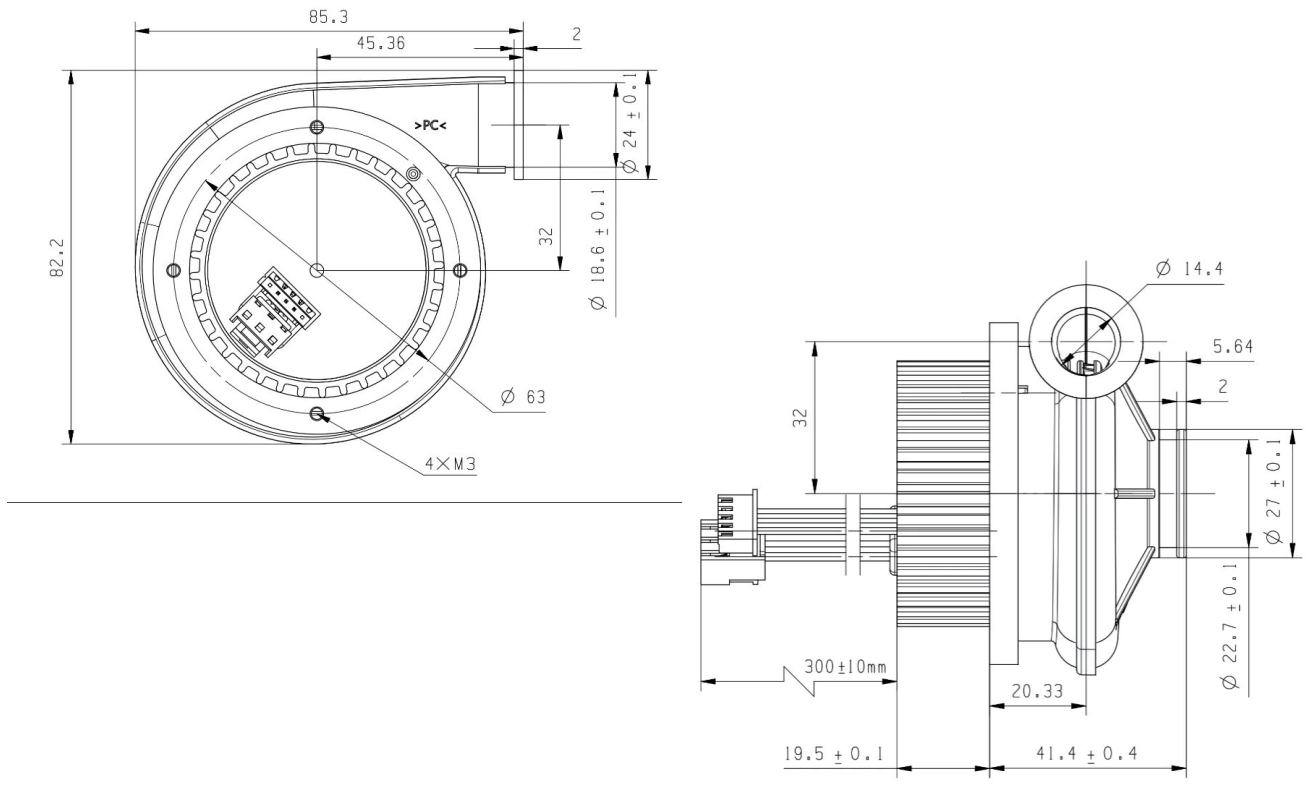

Series Name

C80

Motor Simplified Name

C8018



PRODUCT PARAMETERS

Item Name	C8018
Brand Name	ANCFLOW
Model Number	C8018-12/24/48V-1
Part Name	Brushless DC Blower
Rated Power (W)	60
Rated Voltage (V)	12/24/48
Power Supply Type	DC
Driver Layout	External
max.Static Pressure	7.5kPa
max.Flow Rate	670LPM (40.2m ³ /h)
Rated Static Pressure	5.4kPa
Rated Flow Rate	328LPM (19.7m ³ /h)
Temperature Range(ambient)	-20°C~+50°C
Humidity Range(ambient)	≤85%RH
Size	85.3*82.2*60.9mm
Service life (L10 at 40)	20,000h
Certification	RoHS, CE, ISO10993
Application Field	medical smoke removal equipment, ventilator, hydrogen fuel cell, cold chain sterilization equipment, disinfection and sterilization equipment, oxygen generator, dental equipment, negative pressure isolation chamber, PARR, moxibustion smoking, household fresh air system, temperature and humidity control, environmental monitoring equipment, gas detector, air cushion aerator, glove box, industrial smoke/dust removal equipment, liquid atomization, cooling and drying equipment, agricultural machinery, fishery aerator, etc.

■ PERFORMANCE CURVES

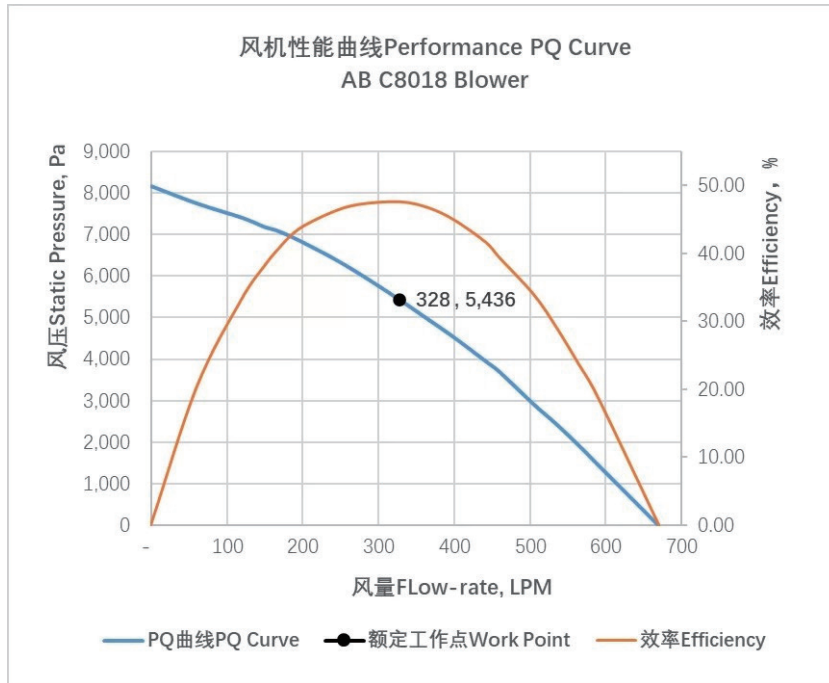

■ INTERFACE DRAWING

C80-1/C80-2 Series

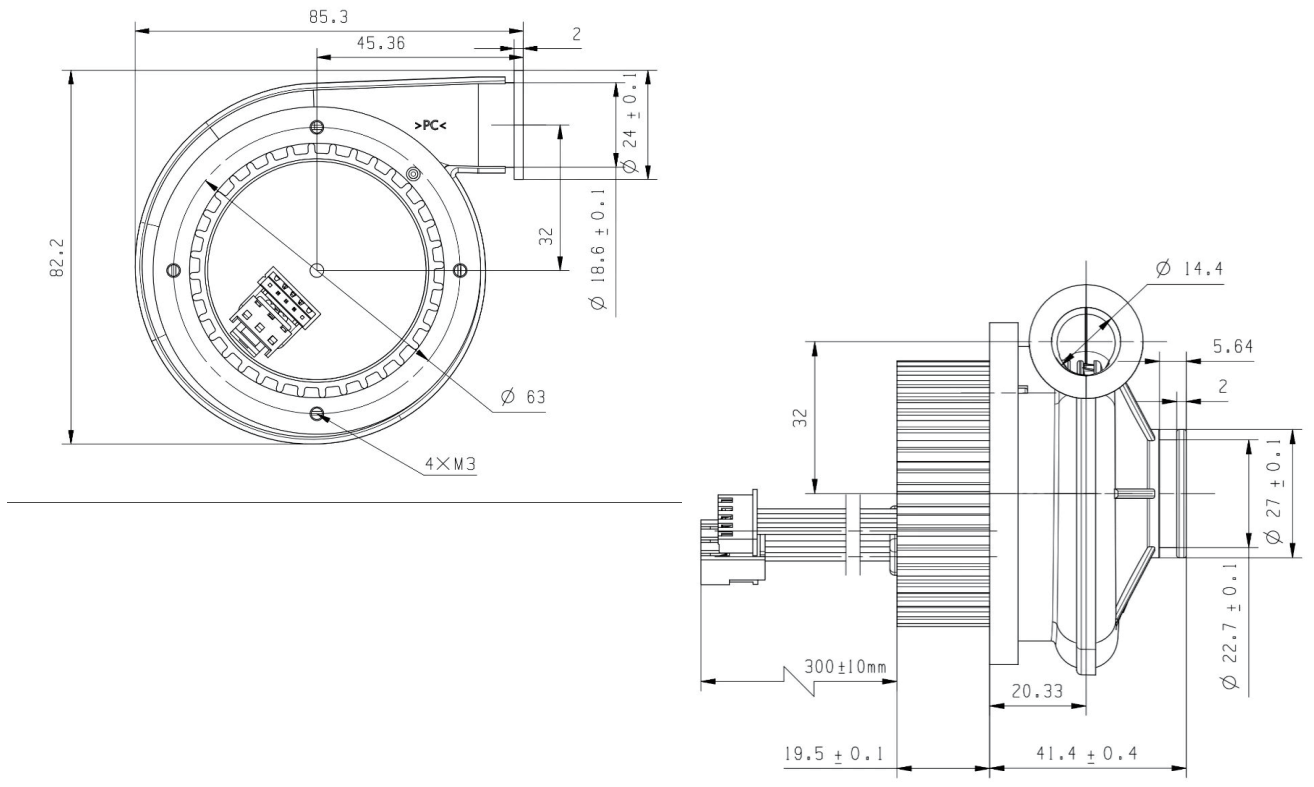

Series Name

C80

Motor Simplified Name

C8019



PRODUCT PARAMETERS

Item Name	C8019
Brand Name	ANCFLOW
Model Number	C8019-24V-1
Part Name	Brushless DC Blower
Rated Power (W)	41
Rated Voltage (V)	24
Power Supply Type	DC
Driver Layout	External
max.Static Pressure	6.0kPa
max.Flow Rate	575LPM (34.5m ³ /h)
Rated Static Pressure	4.4kPa
Rated Flow Rate	238LPM (14.3m ³ /h)
Temperature Range(ambient)	-20°C~+50°C
Humidity Range(ambient)	≤85%RH
Size	85.3*82.2*60.9mm
Service life (L10 at 40)	20,000h
Certification	RoHS, CE, ISO10993
Application Field	medical smoke removal equipment, ventilator, hydrogen fuel cell, cold chain sterilization equipment, disinfection and sterilization equipment, oxygen generator, dental equipment, negative pressure isolation chamber, PARR, moxibustion smoking, household fresh air system, temperature and humidity control, environmental monitoring equipment, gas detector, air cushion aerator, glove box, industrial smoke/dust removal equipment, liquid atomization, cooling and drying equipment, agricultural machinery, fishery aerator, etc.

■ PERFORMANCE CURVES

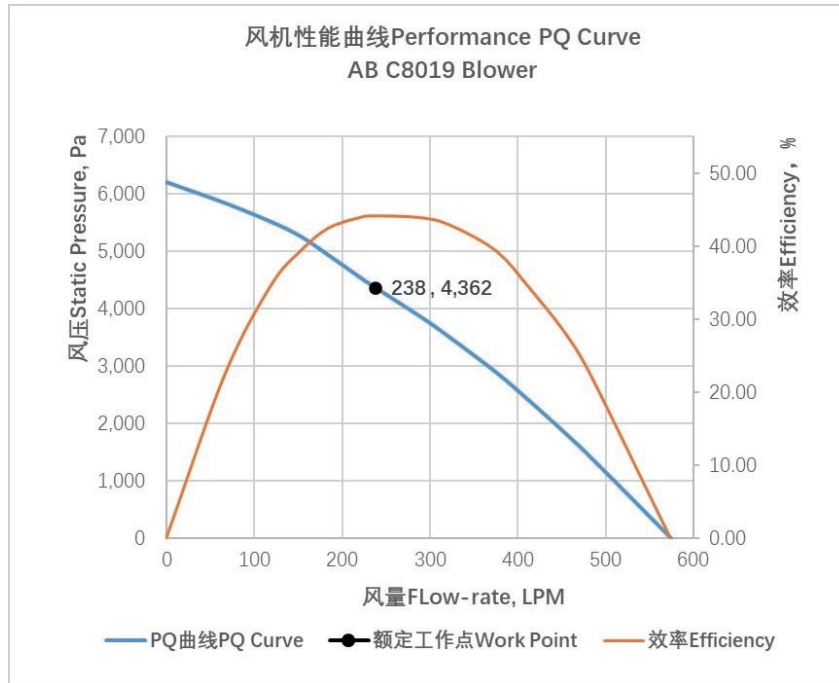

■ INTERFACE DRAWING

C80-1/C80-2 Series

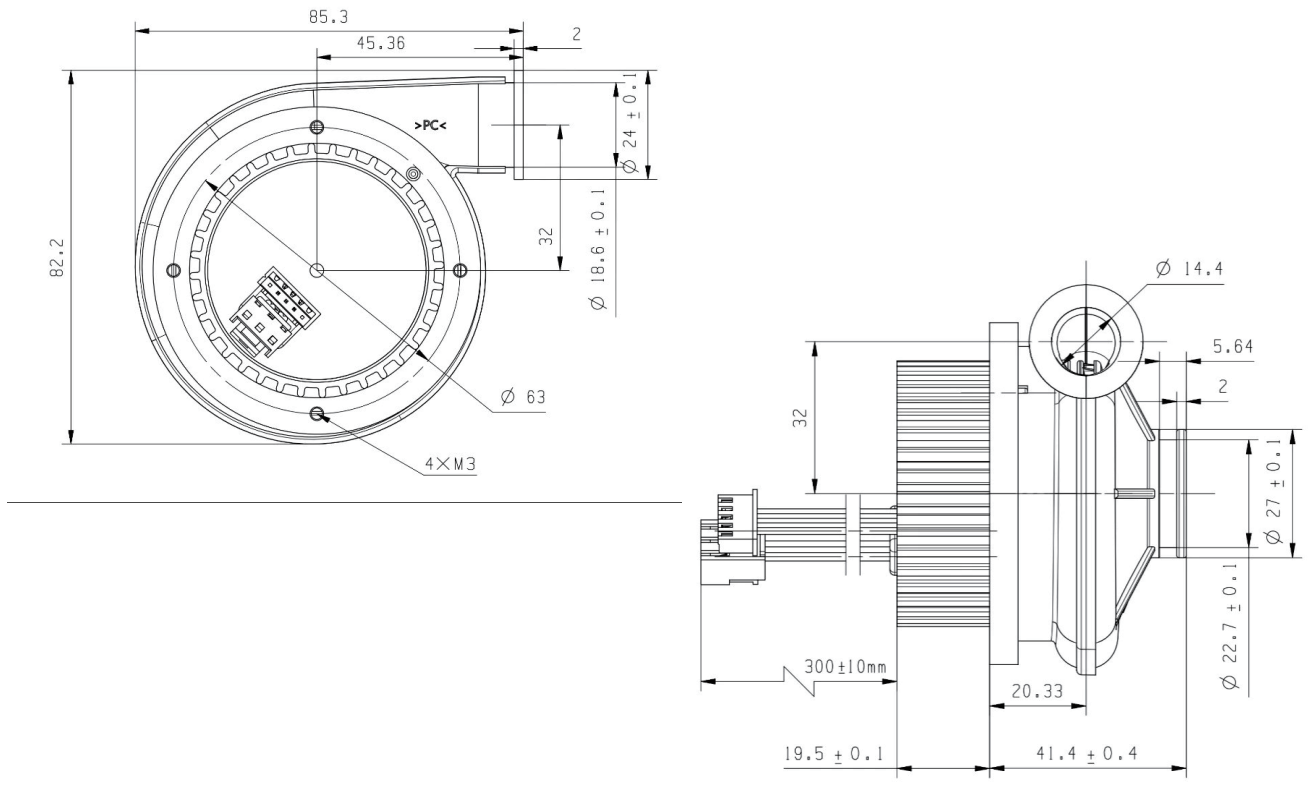

Series Name

C80

Motor Simplified Name

C8020



PRODUCT PARAMETERS

Item Name	C8020
Brand Name	ANCFLOW
Model Number	C8020-12/24/48V-1
Part Name	Brushless DC Blower
Rated Power (W)	41
Rated Voltage (V)	12/24/48
Power Supply Type	DC
Driver Layout	External
max.Static Pressure	6.0kPa
max.Flow Rate	575LPM (34.5m ³ /h)
Rated Static Pressure	4.4kPa
Rated Flow Rate	238LPM (14.3m ³ /h)
Temperature Range(ambient)	-20°C~+50°C
Humidity Range(ambient)	≤85%RH
Size	85.3*82.2*60.9mm
Service life (L10 at 40)	20,000h
Certification	RoHS, CE, ISO10993
Application Field	medical smoke removal equipment, ventilator, hydrogen fuel cell, cold chain sterilization equipment, disinfection and sterilization equipment, oxygen generator, dental equipment, negative pressure isolation chamber, PARR, moxibustion smoking, household fresh air system, temperature and humidity control, environmental monitoring equipment, gas detector, air cushion aerator, glove box, industrial smoke/dust removal equipment, liquid atomization, cooling and drying equipment, agricultural machinery, fishery aerator, etc.

■ PERFORMANCE CURVES

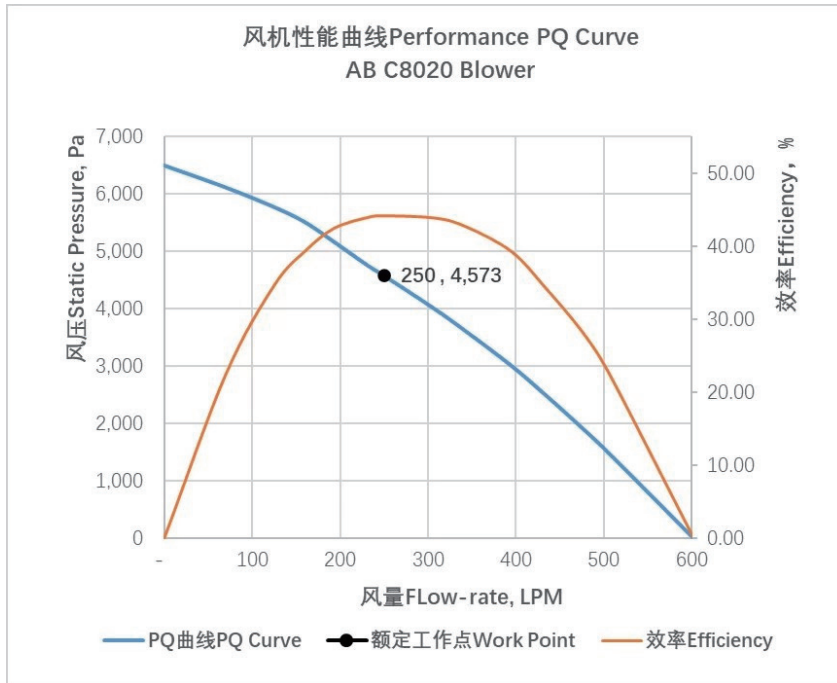

■ INTERFACE DRAWING

C80-1/C80-2 Series

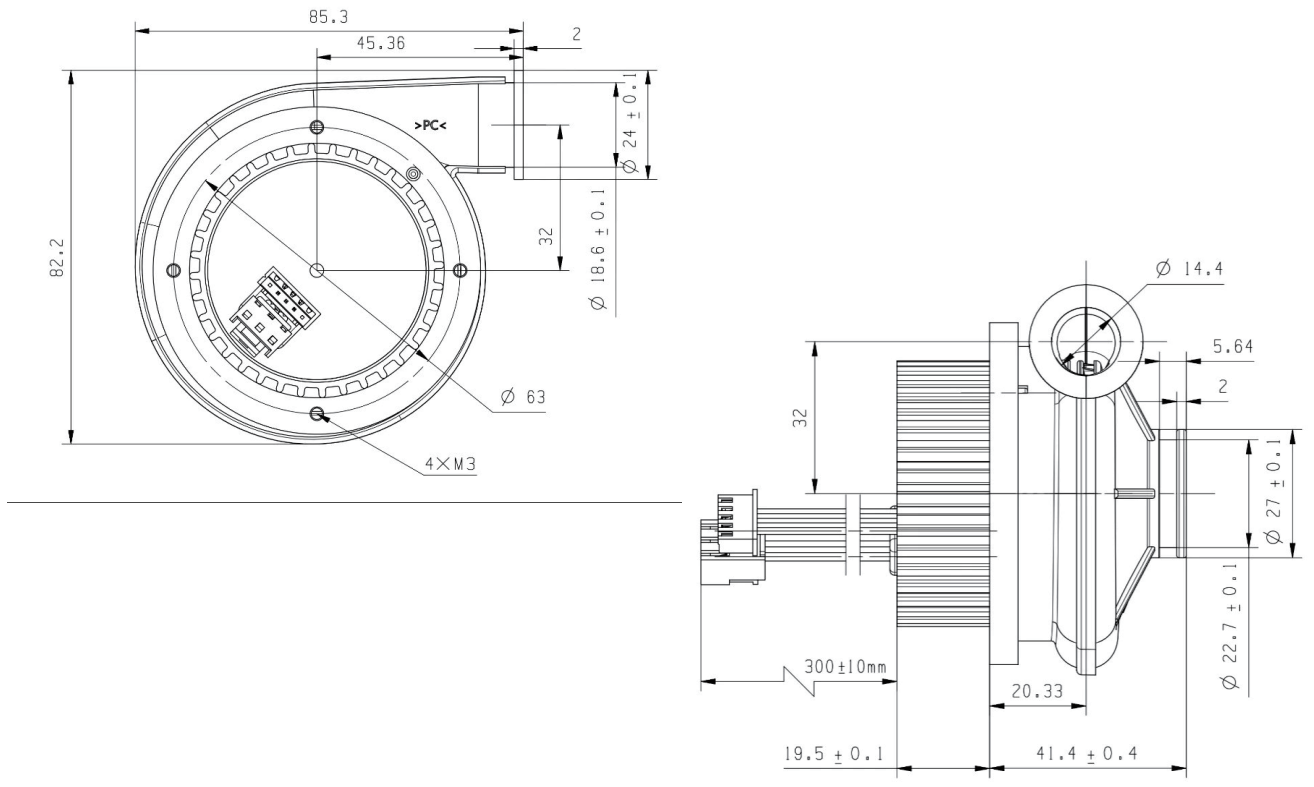

Series Name

C90

Motor Simplified Name

C9001



PRODUCT PARAMETERS

Item Name	C9001
Brand Name	ANCFLOW
Model Number	C9001-24V-1
Part Name	Brushless DC Blower
Rated Power (W)	135
Rated Voltage (V)	24
Power Supply Type	DC
Driver Layout	External
max.Static Pressure	10.5kPa
max.Flow Rate	1,150LPM (69.0m ³ /h)
Rated Static Pressure	7.5kPa
Rated Flow Rate	447LPM (26.8m ³ /h)
Temperature Range(ambient)	-20°C~+50°C
Humidity Range(ambient)	≤85%RH
Size	103.2*95.4*69.3mm
Service life (L10 at 40)	20,000h
Certification	RoHS, CE
Application Field	medical smoke removal equipment, ventilator, hydrogen fuel cell, cold chain sterilization equipment, disinfection and sterilization equipment, oxygen generator, dental equipment, negative pressure isolation chamber, PARR, moxibustion smoking, household fresh air system, temperature and humidity control, environmental monitoring equipment, gas detector, air cushion aerator, glove box, industrial smoke/dust removal equipment, liquid atomization, cooling and drying equipment, agricultural machinery, fishery aerator, etc.

■ PERFORMANCE CURVES

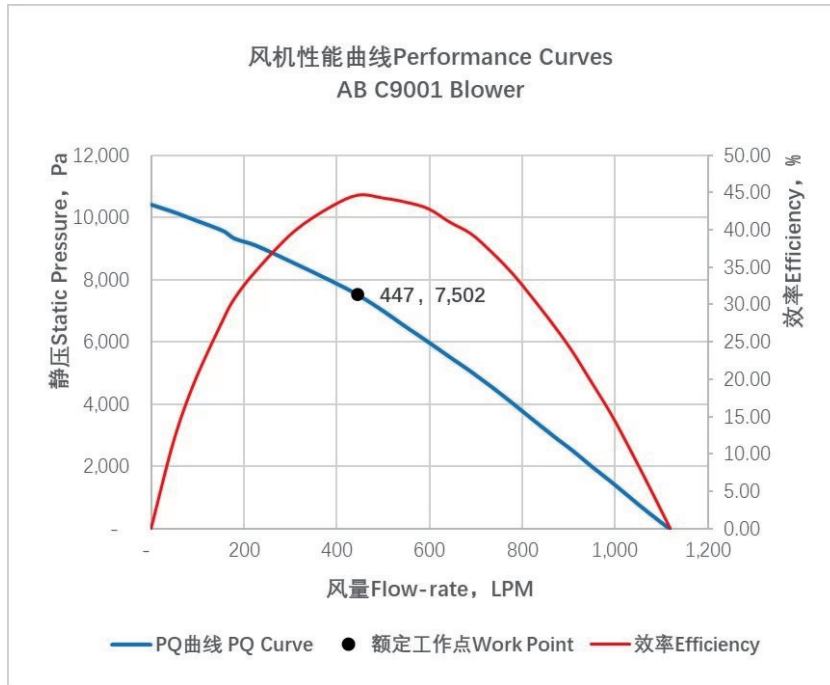

■ INTERFACE DRAWING

C90-1/C90-2 Series

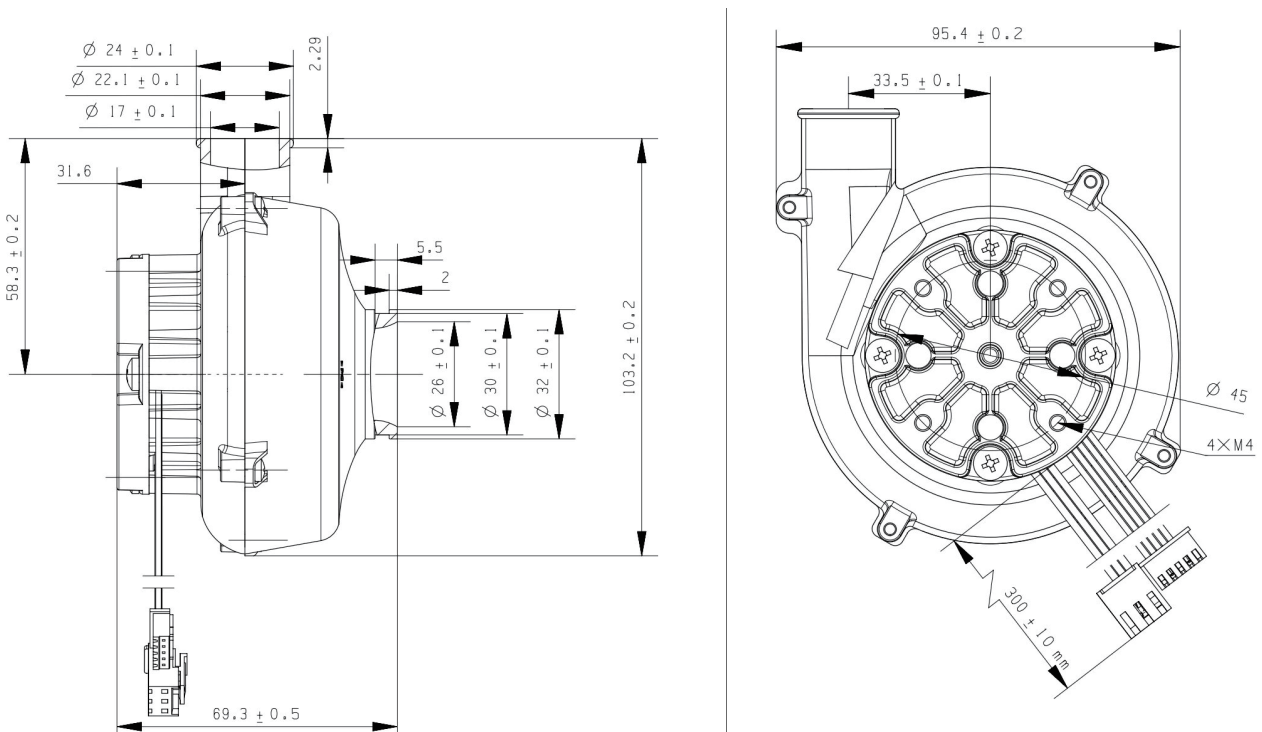

Series Name

C90

Motor Simplified Name

C9002



PRODUCT PARAMETERS

Item Name	C9002
Brand Name	ANCFLOW
Model Number	C9002-24/48V-1
Part Name	Brushless DC Blower
Rated Power (W)	135
Rated Voltage (V)	24/48
Power Supply Type	DC
Driver Layout	External
max.Static Pressure	10.5kPa
max.Flow Rate	1,160LPM (69.6m ³ /h)
Rated Static Pressure	7.4kPa
Rated Flow Rate	502LPM (30.1m ³ /h)
Temperature Range(ambient)	-20°C~+50°C
Humidity Range(ambient)	≤85%RH
Size	103.2*95.4*69.3mm
Service life (L10 at 40)	20,000h
Certification	RoHS, CE
Application Field	medical smoke removal equipment, ventilator, hydrogen fuel cell, cold chain sterilization equipment, disinfection and sterilization equipment, oxygen generator, dental equipment, negative pressure isolation chamber, PARR, moxibustion smoking, household fresh air system, temperature and humidity control, environmental monitoring equipment, gas detector, air cushion aerator, glove box, industrial smoke/dust removal equipment, liquid atomization, cooling and drying equipment, agricultural machinery, fishery aerator, etc.

■ PERFORMANCE CURVES

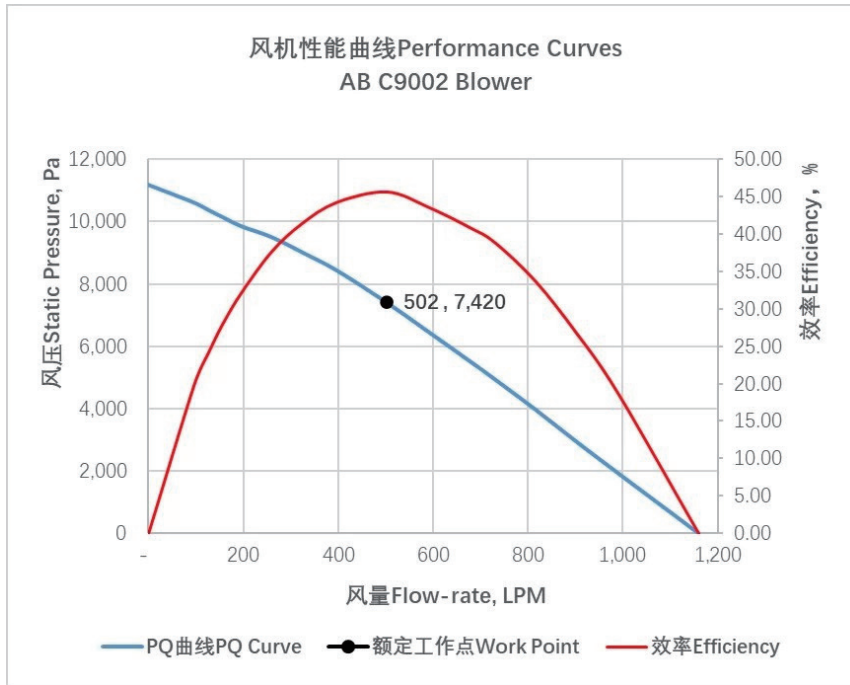

■ INTERFACE DRAWING

C90-1/C90-2 Series

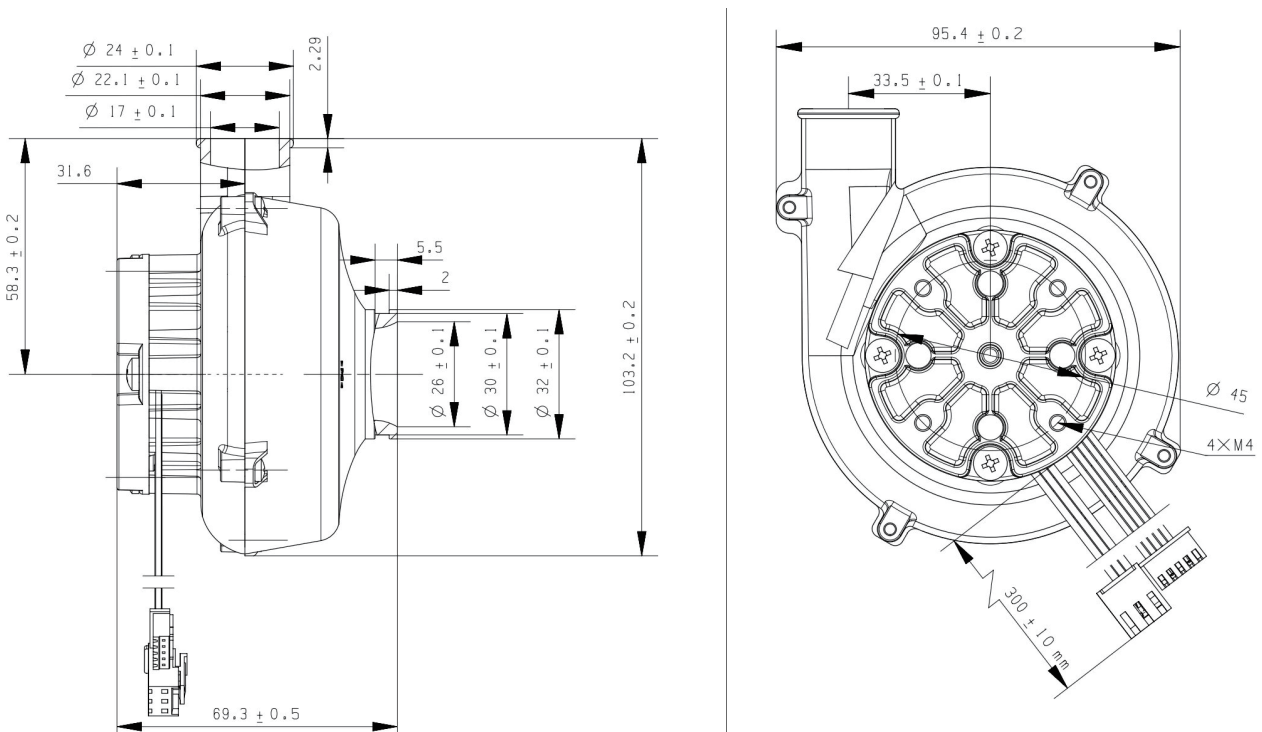

Series Name

C90

Motor Simplified Name

C9002U

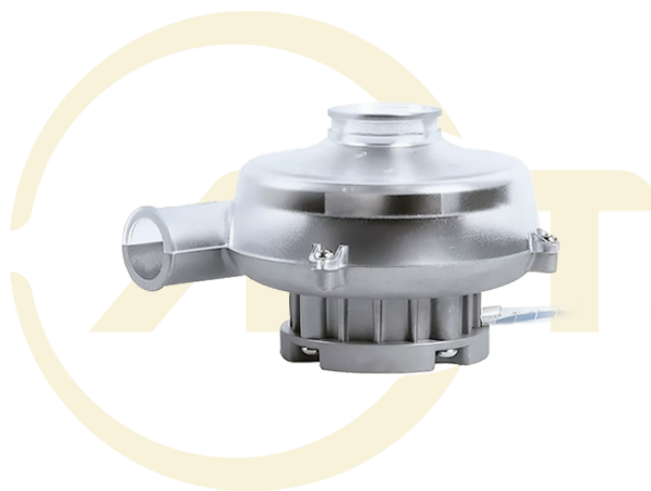

PRODUCT PARAMETERS

Item Name	C9002U
Brand Name	ANCFLOW
Model Number	C9002U-24V-1
Part Name	Brushless DC Blower
Rated Power (W)	145
Rated Voltage (V)	24/48
Power Supply Type	DC
Driver Layout	External
max.Static Pressure	12.0kPa
max.Flow Rate	1,190LPM (71.4m ³ /h)
Rated Static Pressure	8.0kPa
Rated Flow Rate	500LPM (30.0m ³ /h)
Temperature Range(ambient)	-20°C~+50°C
Humidity Range(ambient)	≤85%RH
Size	103.2*95.4*69.3mm
Service life (L10 at 40)	20,000h
Certification	RoHS, CE
Application Field	medical smoke removal equipment, ventilator, hydrogen fuel cell, cold chain sterilization equipment, disinfection and sterilization equipment, oxygen generator, dental equipment, negative pressure isolation chamber, PARR, moxibustion smoking, household fresh air system, temperature and humidity control, environmental monitoring equipment, gas detector, air cushion aerator, glove box, industrial smoke/dust removal equipment, liquid atomization, cooling and drying equipment, agricultural machinery, fishery aerator, etc.

■ PERFORMANCE CURVES

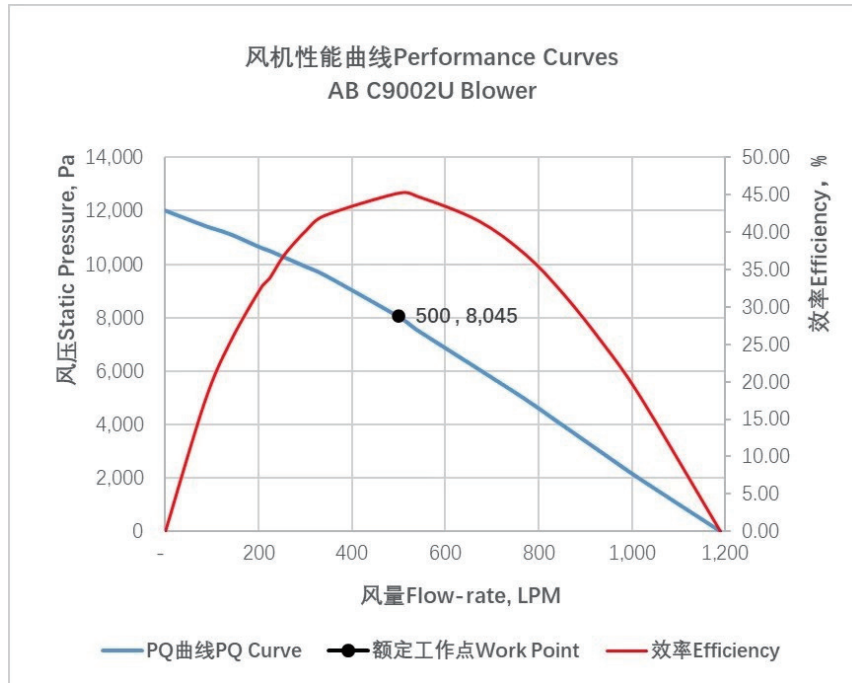

■ INTERFACE DRAWING

C90-1/C90-2 Series

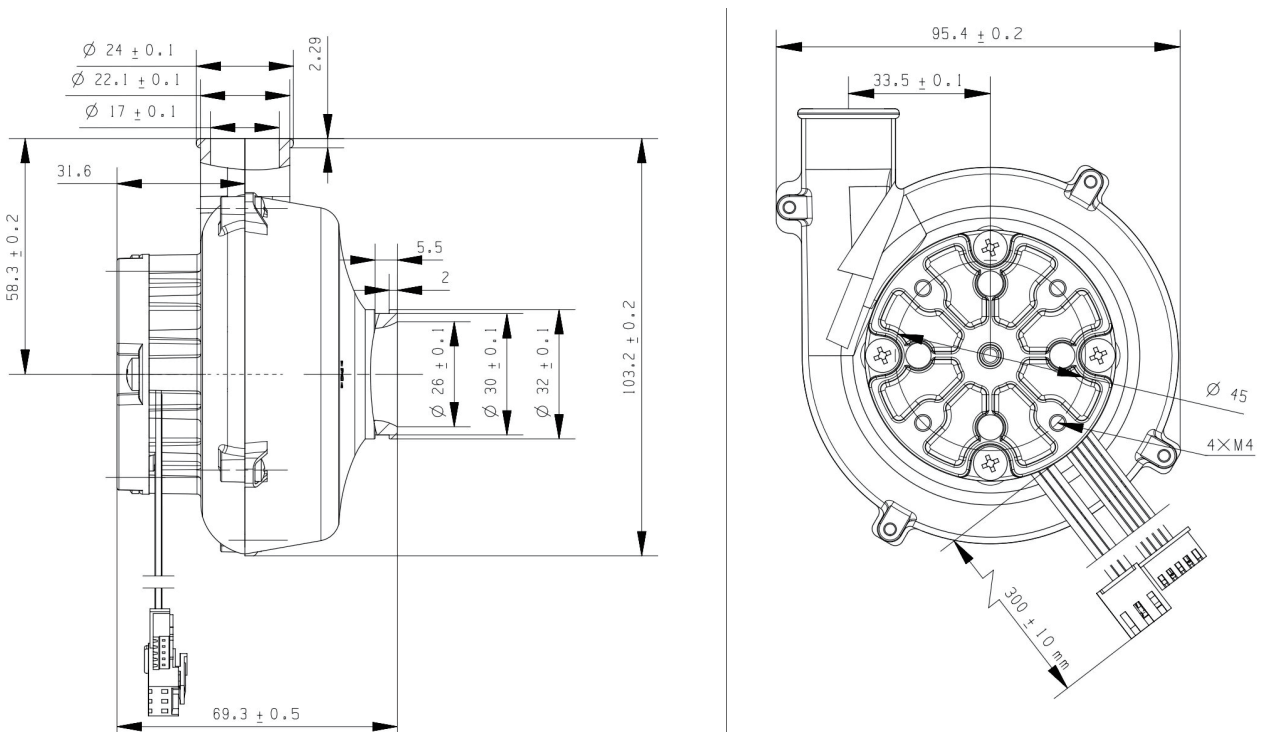

Series Name

C90

Motor Simplified Name

C9003

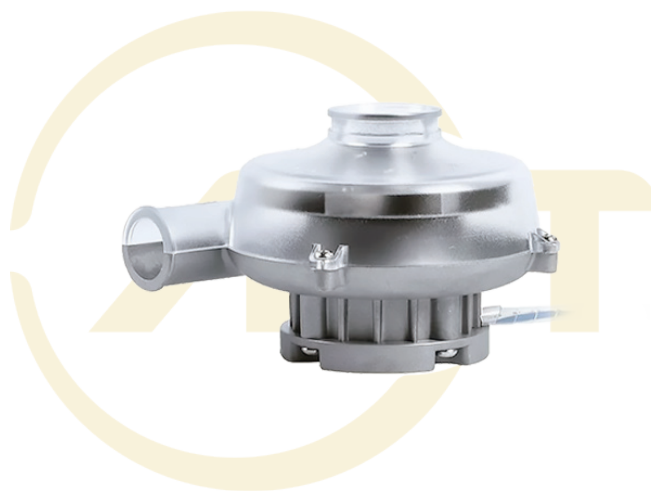

PRODUCT PARAMETERS

Item Name	C9003
Brand Name	ANCFLOW
Model Number	C9003-24V-1
Part Name	Brushless DC Blower
Rated Power (W)	99
Rated Voltage (V)	24
Power Supply Type	DC
Driver Layout	External
max.Static Pressure	8.5kPa
max.Flow Rate	1,120LPM (67.2m ³ /h)
Rated Static Pressure	6.0kPa
Rated Flow Rate	453LPM (27.2m ³ /h)
Temperature Range(ambient)	-20°C~+50°C
Humidity Range(ambient)	≤85%RH
Size	103.2*95.4*69.3mm
Service life (L10 at 40)	20,000h
Certification	RoHS, CE
Application Field	medical smoke removal equipment, ventilator, hydrogen fuel cell, cold chain sterilization equipment, disinfection and sterilization equipment, oxygen generator, dental equipment, negative pressure isolation chamber, PARR, moxibustion smoking, household fresh air system, temperature and humidity control, environmental monitoring equipment, gas detector, air cushion aerator, glove box, industrial smoke/dust removal equipment, liquid atomization, cooling and drying equipment, agricultural machinery, fishery aerator, etc.

■ PERFORMANCE CURVES

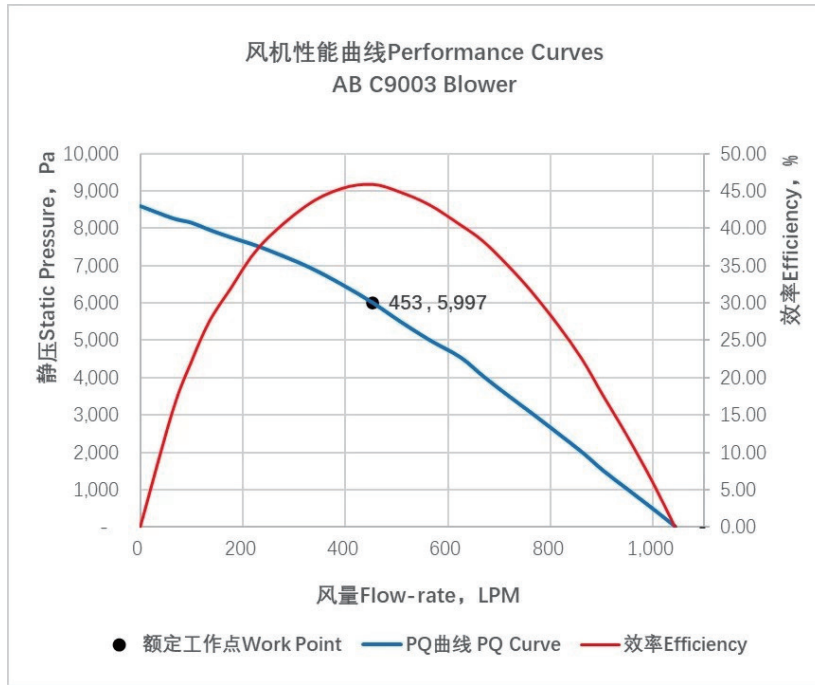

■ INTERFACE DRAWING

C90-1/C90-2 Series

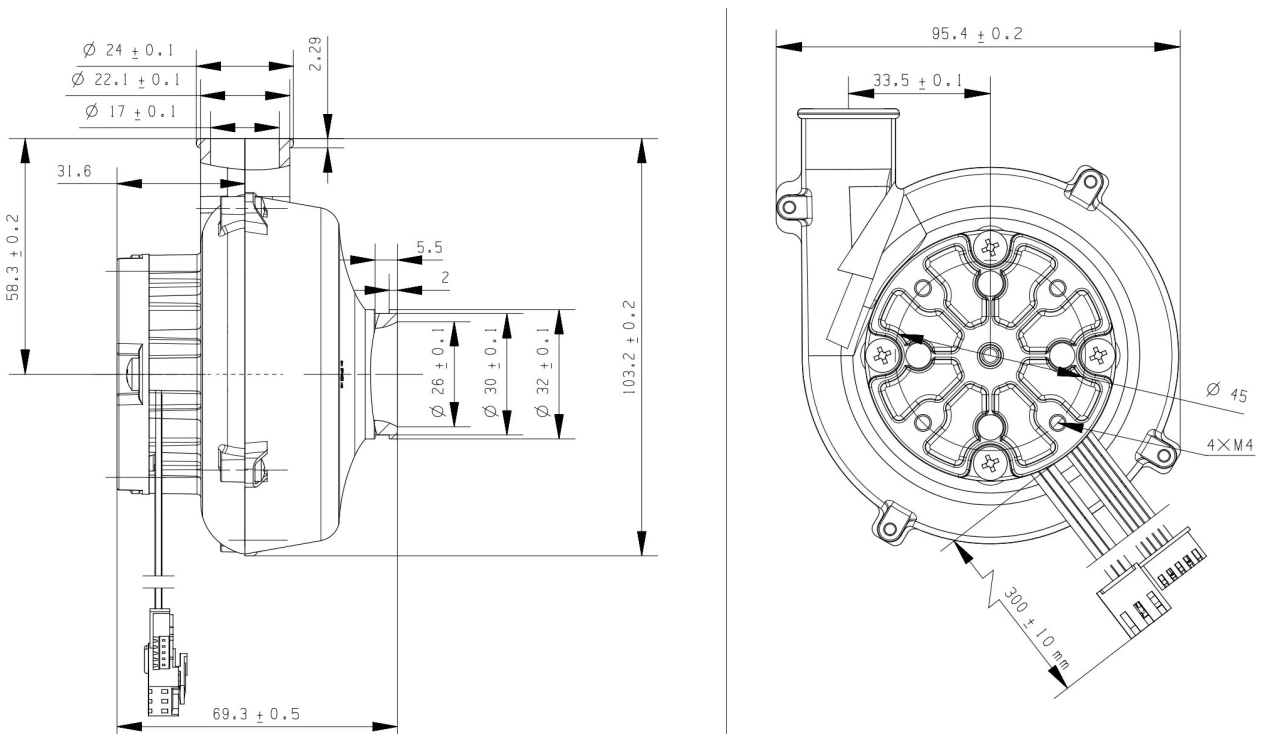

Series Name

C90

Motor Simplified Name

C9004

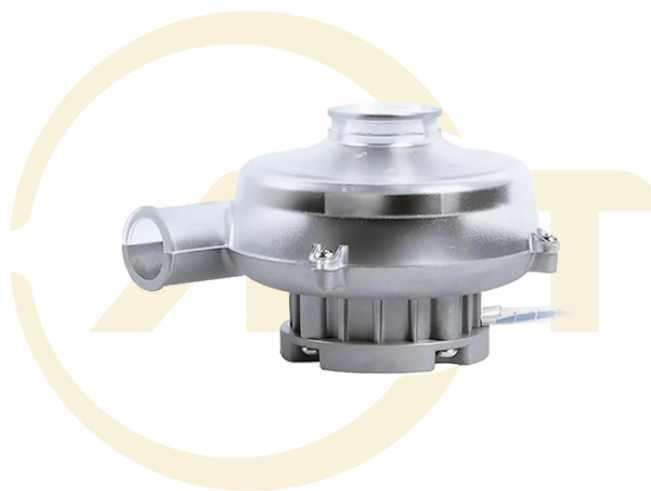

PRODUCT PARAMETERS

Item Name	C9004
Brand Name	ANCFLOW
Model Number	C9004-24V-1
Part Name	Brushless DC Blower
Rated Power (W)	95
Rated Voltage (V)	24
Power Supply Type	DC
Driver Layout	External
max.Static Pressure	8.5kPa
max.Flow Rate	1,070LPM (64.2m ³ /h)
Rated Static Pressure	6.7kPa
Rated Flow Rate	398LPM (23.9m ³ /h)
Temperature Range(ambient)	-20°C~+50°C
Humidity Range(ambient)	≤85%RH
Size	103.2*95.4*69.3mm
Service life (L10 at 40)	20,000h
Certification	RoHS, CE
Application Field	medical smoke removal equipment, ventilator, hydrogen fuel cell, cold chain sterilization equipment, disinfection and sterilization equipment, oxygen generator, dental equipment, negative pressure isolation chamber, PARR, moxibustion smoking, household fresh air system, temperature and humidity control, environmental monitoring equipment, gas detector, air cushion aerator, glove box, industrial smoke/dust removal equipment, liquid atomization, cooling and drying equipment, agricultural machinery, fishery aerator, etc.

■ PERFORMANCE CURVES

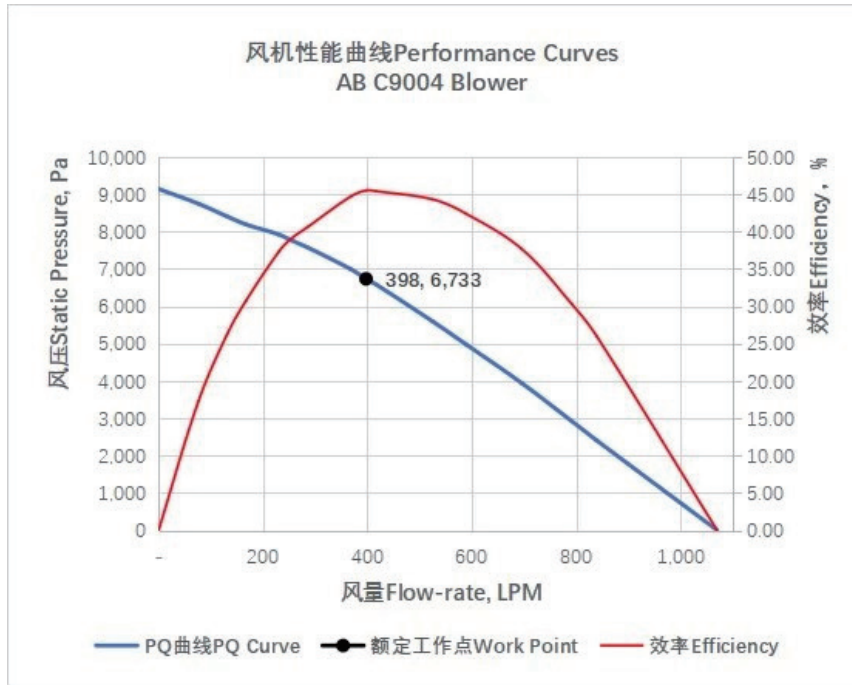

■ INTERFACE DRAWING

C90-1/C90-2 Series

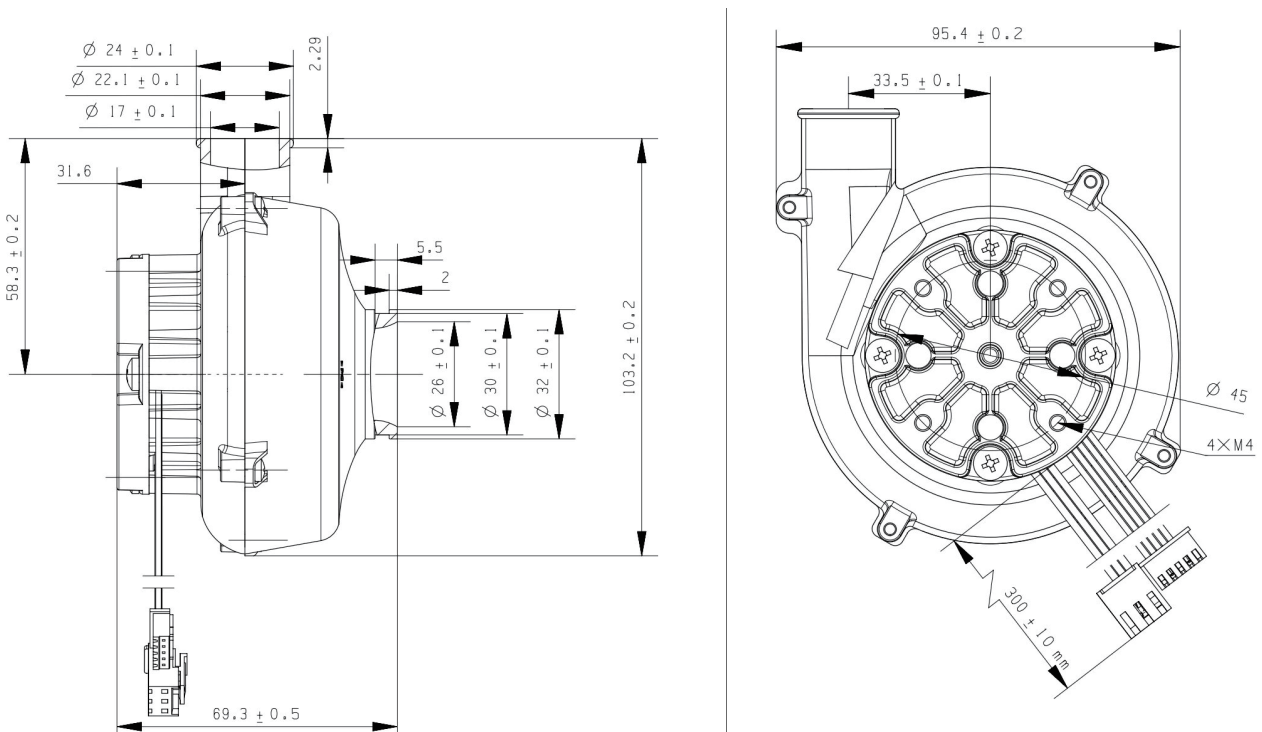

Series Name

C90

Motor Simplified Name

C9005

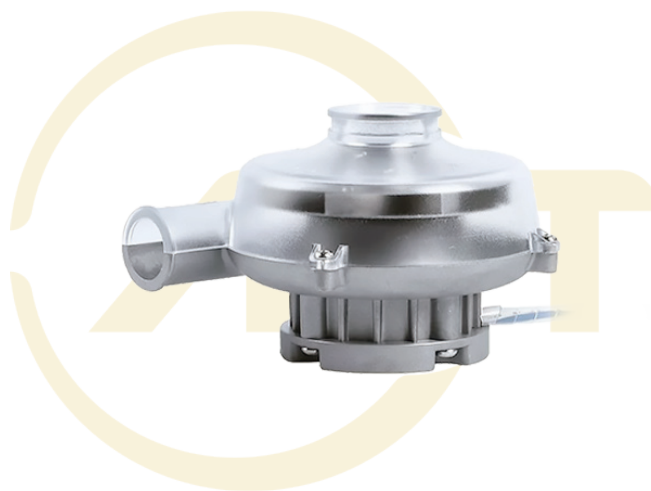

PRODUCT PARAMETERS

Item Name	C9005
Brand Name	ANCFLOW
Model Number	C9005-24V-1
Part Name	Brushless DC Blower
Rated Power (W)	82
Rated Voltage (V)	24
Power Supply Type	DC
Driver Layout	External
max.Static Pressure	7.5kPa
max.Flow Rate	980LPM (58.8m ³ /h)
Rated Static Pressure	5.5kPa
Rated Flow Rate	408LPM (24.5m ³ /h)
Temperature Range(ambient)	-20°C~+50°C
Humidity Range(ambient)	≤85%RH
Size	103.2*95.4*69.3mm
Service life (L10 at 40)	20,000h
Certification	RoHS, CE
Application Field	medical smoke removal equipment, ventilator, hydrogen fuel cell, cold chain sterilization equipment, disinfection and sterilization equipment, oxygen generator, dental equipment, negative pressure isolation chamber, PARR, moxibustion smoking, household fresh air system, temperature and humidity control, environmental monitoring equipment, gas detector, air cushion aerator, glove box, industrial smoke/dust removal equipment, liquid atomization, cooling and drying equipment, agricultural machinery, fishery aerator, etc.

■ PERFORMANCE CURVES

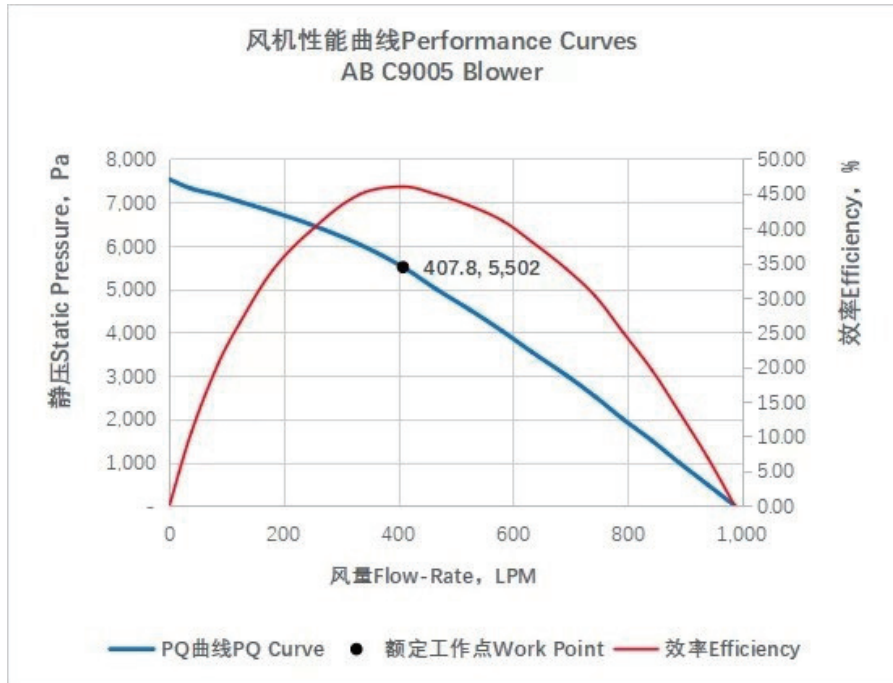

■ INTERFACE DRAWING

C90-1/C90-2 Series

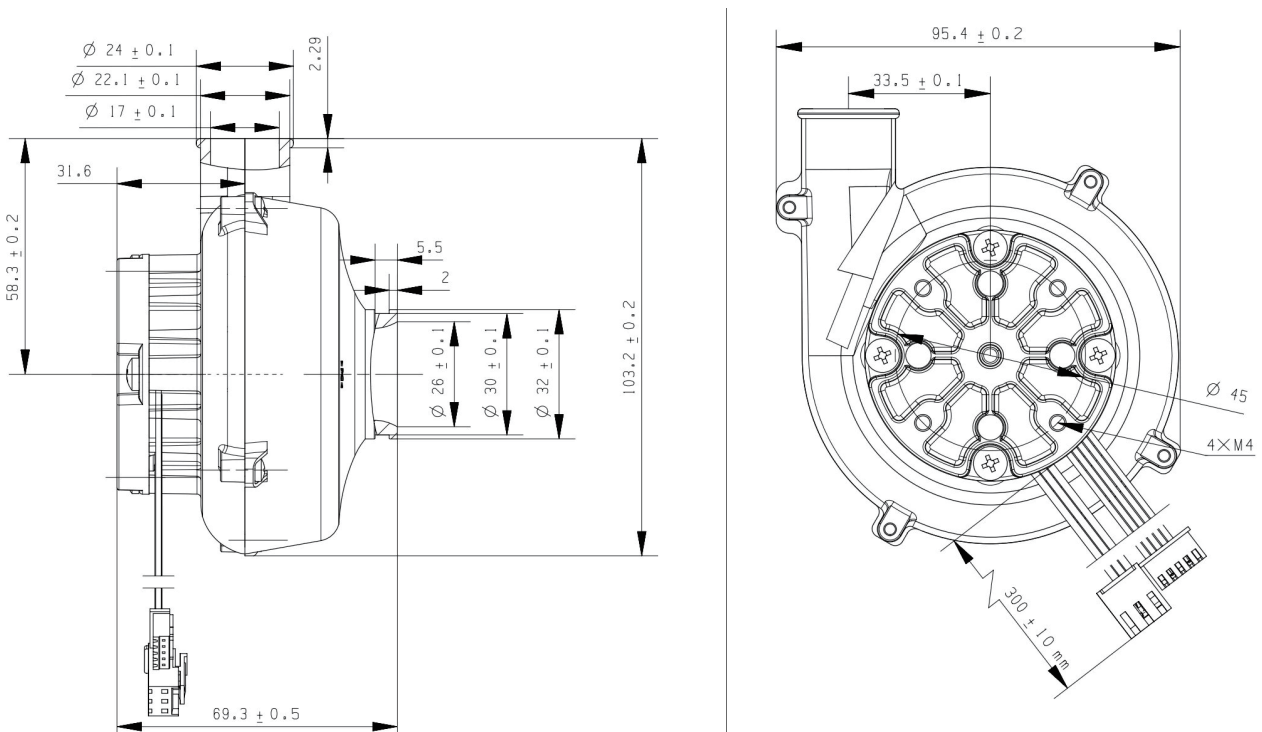

Series Name

C90

Motor Simplified Name

C9006

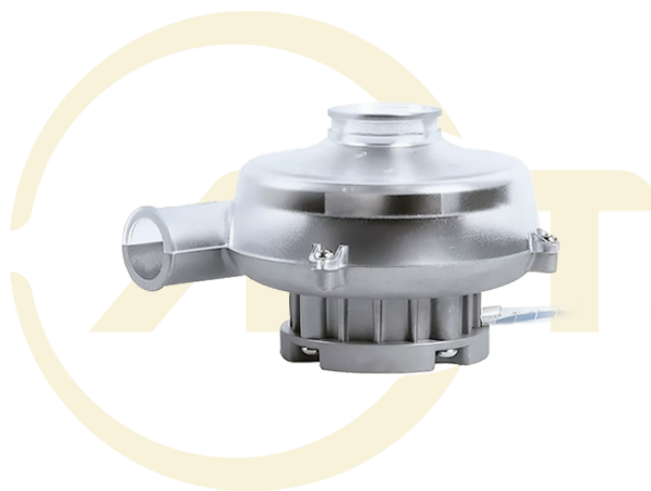

PRODUCT PARAMETERS

Item Name	C9006
Brand Name	ANCFLOW
Model Number	C9006-12/24/48V-1
Part Name	Brushless DC Blower
Rated Power (W)	85
Rated Voltage (V)	12/24/48
Power Supply Type	DC
Driver Layout	External
max.Static Pressure	7.5kPa
max.Flow Rate	1.024LPM (61.4m ³ /h)
Rated Static Pressure	5.9kPa
Rated Flow Rate	407LPM (24.4m ³ /h)
Temperature Range(ambient)	-20°C~+50°C
Humidity Range(ambient)	≤85%RH
Size	103.2*95.4*69.3mm
Service life (L10 at 40)	20,000h
Certification	RoHS, CE
Application Field	medical smoke removal equipment, ventilator, hydrogen fuel cell, cold chain sterilization equipment, disinfection and sterilization equipment, oxygen generator, dental equipment, negative pressure isolation chamber, PARR, moxibustion smoking, household fresh air system, temperature and humidity control, environmental monitoring equipment, gas detector, air cushion aerator, glove box, industrial smoke/dust removal equipment, liquid atomization, cooling and drying equipment, agricultural machinery, fishery aerator, etc.

■ PERFORMANCE CURVES

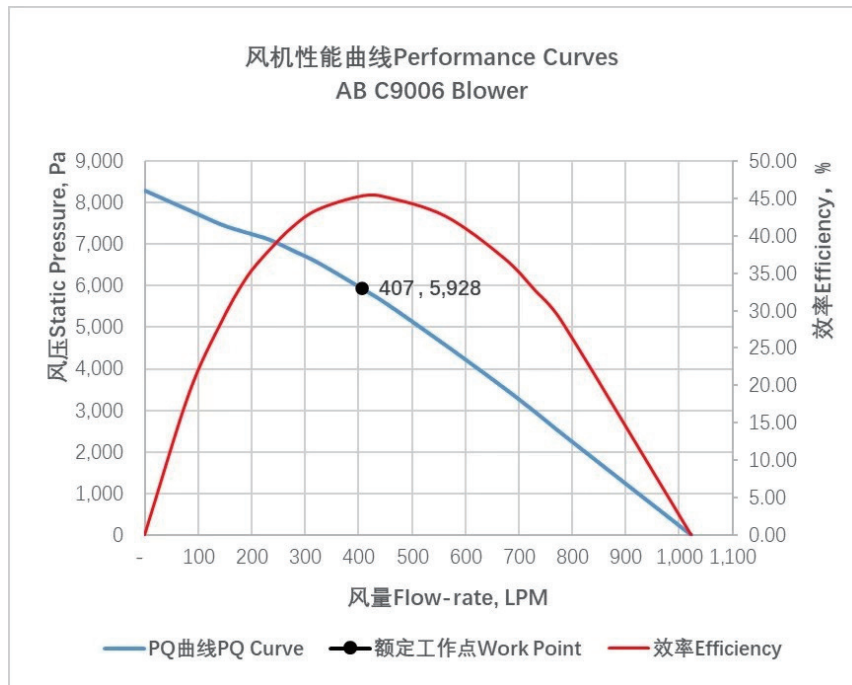

■ INTERFACE DRAWING

C90-1/C90-2 Series

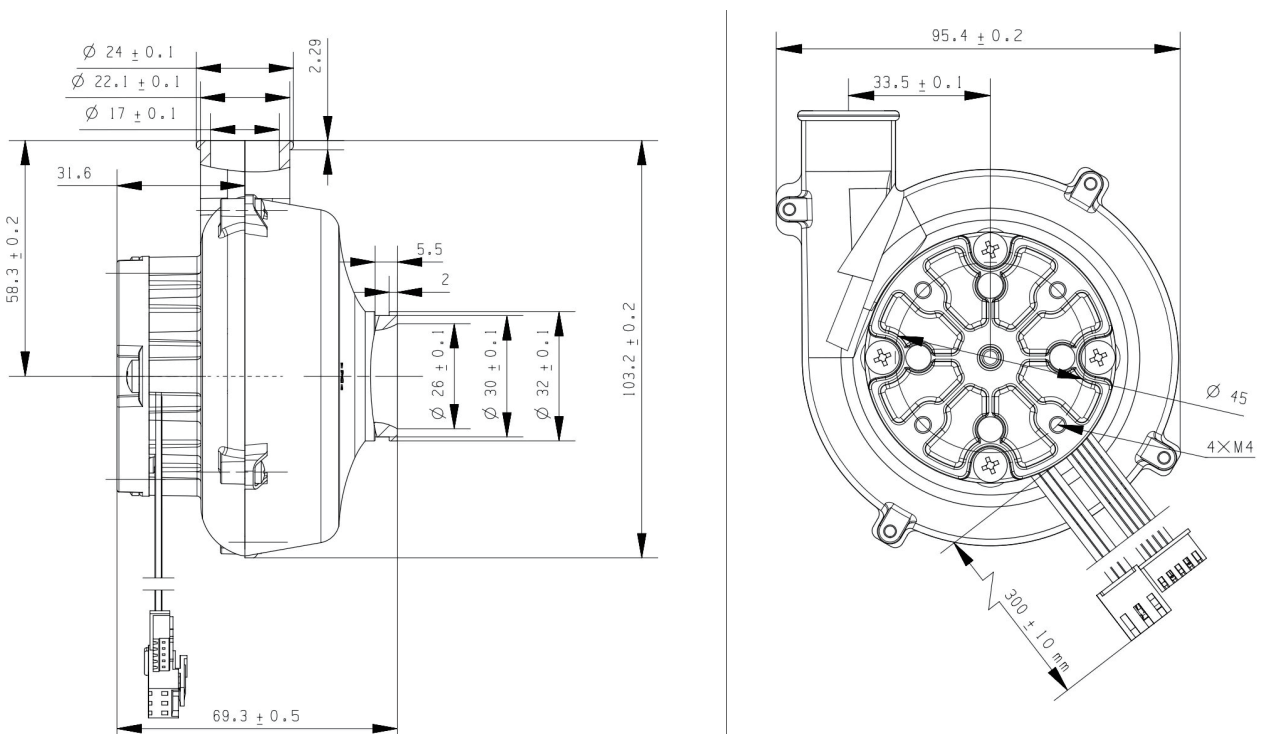

Series Name

C90

Motor Simplified Name

C9007

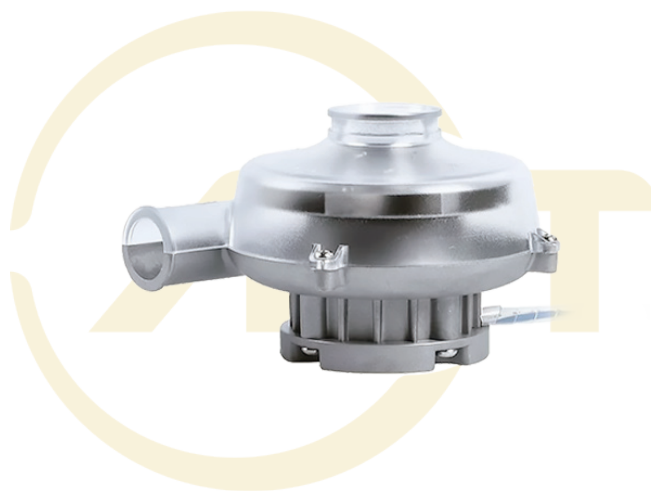

PRODUCT PARAMETERS

Item Name	C9007
Brand Name	ANCFLOW
Model Number	C9007-24V-1
Part Name	Brushless DC Blower
Rated Power (W)	70
Rated Voltage (V)	24
Power Supply Type	DC
Driver Layout	External
max.Static Pressure	6.5kPa
max.Flow Rate	930LPM (55.8m ³ /h)
Rated Static Pressure	5.0kPa
Rated Flow Rate	383LPM (23.0m ³ /h)
Temperature Range(ambient)	-20°C~+50°C
Humidity Range(ambient)	≤85%RH
Size	103.2*95.4*69.3mm
Service life (L10 at 40)	20,000h
Certification	RoHS, CE
Application Field	medical smoke removal equipment, ventilator, hydrogen fuel cell, cold chain sterilization equipment, disinfection and sterilization equipment, oxygen generator, dental equipment, negative pressure isolation chamber, PARR, moxibustion smoking, household fresh air system, temperature and humidity control, environmental monitoring equipment, gas detector, air cushion aerator, glove box, industrial smoke/dust removal equipment, liquid atomization, cooling and drying equipment, agricultural machinery, fishery aerator, etc.

■ PERFORMANCE CURVES

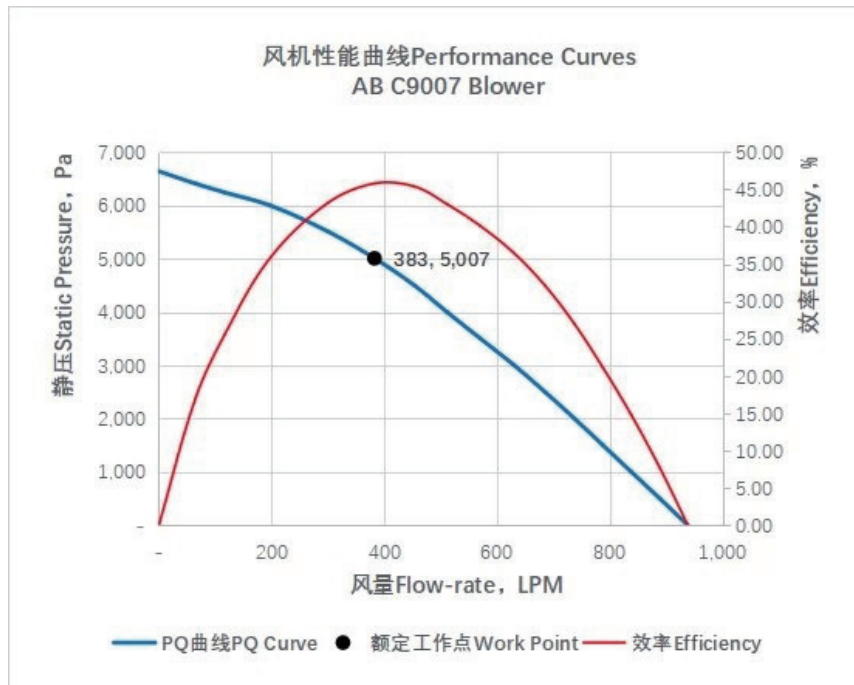

■ INTERFACE DRAWING

C90-1/C90-2 Series

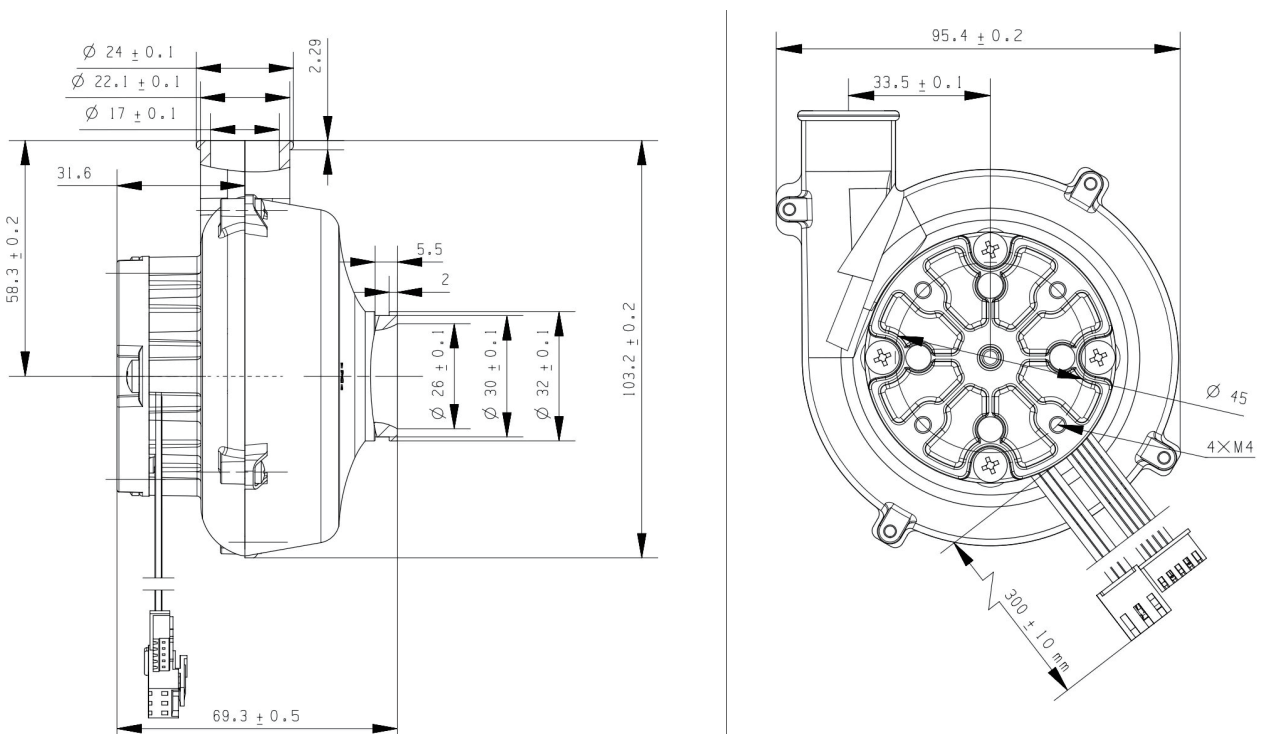

Series Name

C90

Motor Simplified Name

C9008

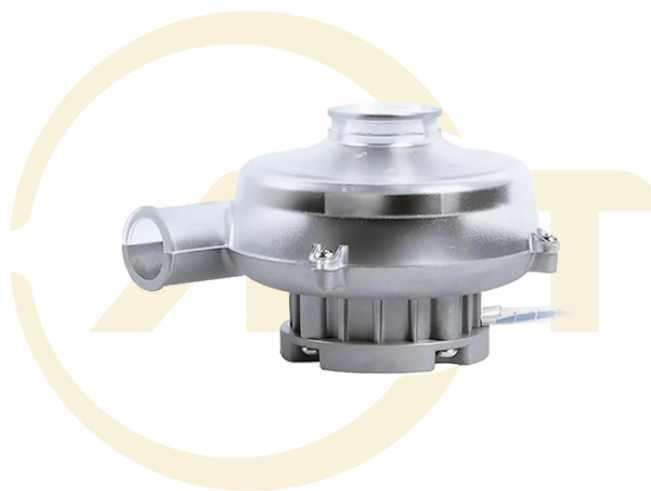

PRODUCT PARAMETERS

Item Name	C9008
Brand Name	ANCFLOW
Model Number	C9008-24V-1
Part Name	Brushless DC Blower
Rated Power (W)	75
Rated Voltage (V)	12/24/48
Power Supply Type	DC
Driver Layout	External
max.Static Pressure	6.5kPa
max.Flow Rate	969LPM (58.1m ³ /h)
Rated Static Pressure	5.0kPa
Rated Flow Rate	422LPM (25.3m ³ /h)
Temperature Range(ambient)	-20°C~+50°C
Humidity Range(ambient)	≤85%RH
Size	103.2*95.4*69.3mm
Service life (L10 at 40)	20,000h
Certification	RoHS, CE
Application Field	medical smoke removal equipment, ventilator, hydrogen fuel cell, cold chain sterilization equipment, disinfection and sterilization equipment, oxygen generator, dental equipment, negative pressure isolation chamber, PARR, moxibustion smoking, household fresh air system, temperature and humidity control, environmental monitoring equipment, gas detector, air cushion aerator, glove box, industrial smoke/dust removal equipment, liquid atomization, cooling and drying equipment, agricultural machinery, fishery aerator, etc.

■ PERFORMANCE CURVES

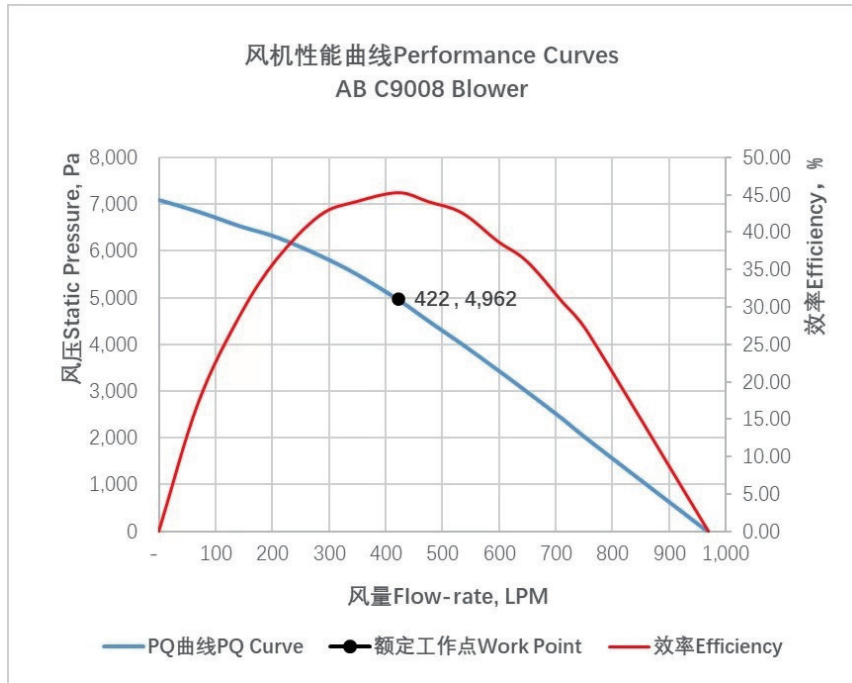

■ INTERFACE DRAWING

C90-1/C90-2 Series

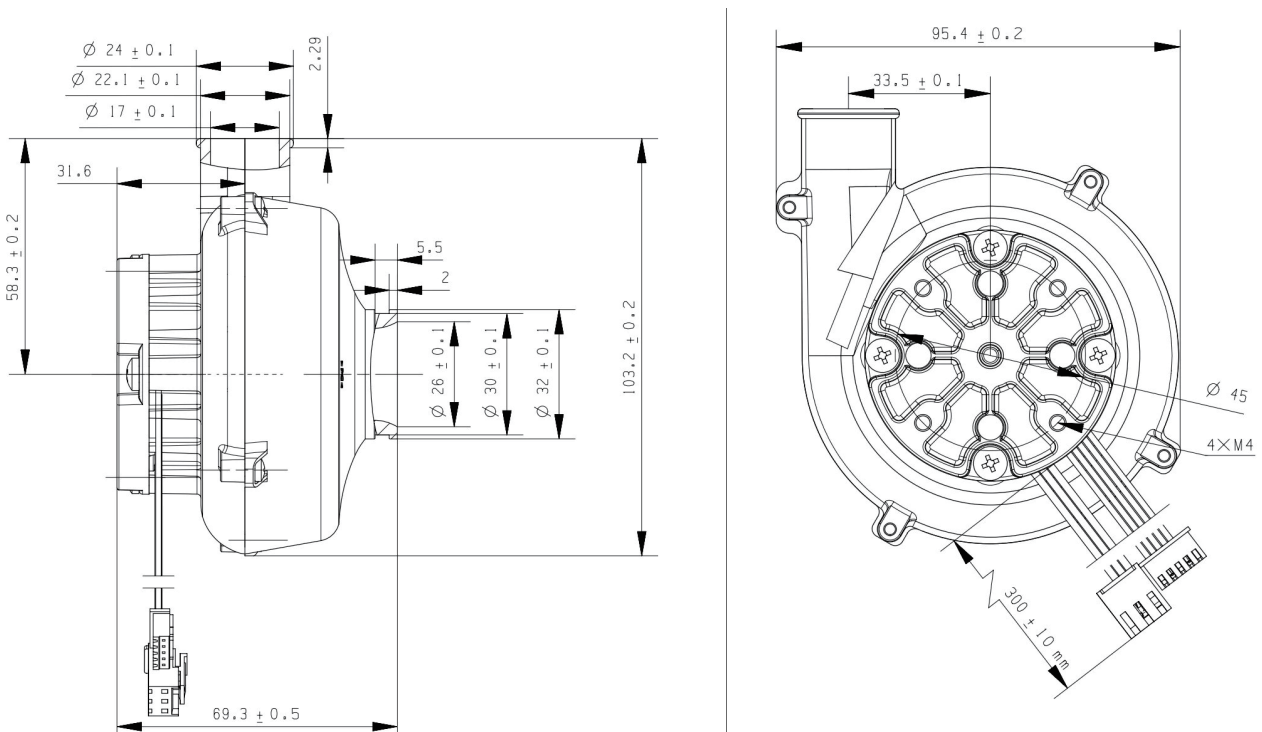

Series Name

C90

Motor Simplified Name

C9009

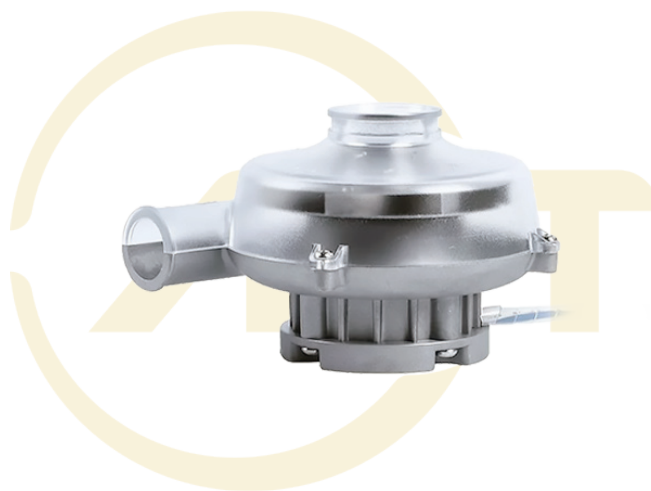

PRODUCT PARAMETERS

Item Name	C9009
Brand Name	ANCFLOW
Model Number	C9009-24V-1
Part Name	Brushless DC Blower
Rated Power (W)	53
Rated Voltage (V)	24
Power Supply Type	DC
Driver Layout	External
max.Static Pressure	5.0kPa
max.Flow Rate	850LPM (51.0m ³ /h)
Rated Static Pressure	4.0kPa
Rated Flow Rate	355LPM (21.3m ³ /h)
Temperature Range(ambient)	-20°C~+50°C
Humidity Range(ambient)	≤85%RH
Size	103.2*95.4*69.3mm
Service life (L10 at 40)	20,000h
Certification	RoHS, CE
Application Field	medical smoke removal equipment, ventilator, hydrogen fuel cell, cold chain sterilization equipment, disinfection and sterilization equipment, oxygen generator, dental equipment, negative pressure isolation chamber, PARR, moxibustion smoking, household fresh air system, temperature and humidity control, environmental monitoring equipment, gas detector, air cushion aerator, glove box, industrial smoke/dust removal equipment, liquid atomization, cooling and drying equipment, agricultural machinery, fishery aerator, etc.

■ PERFORMANCE CURVES

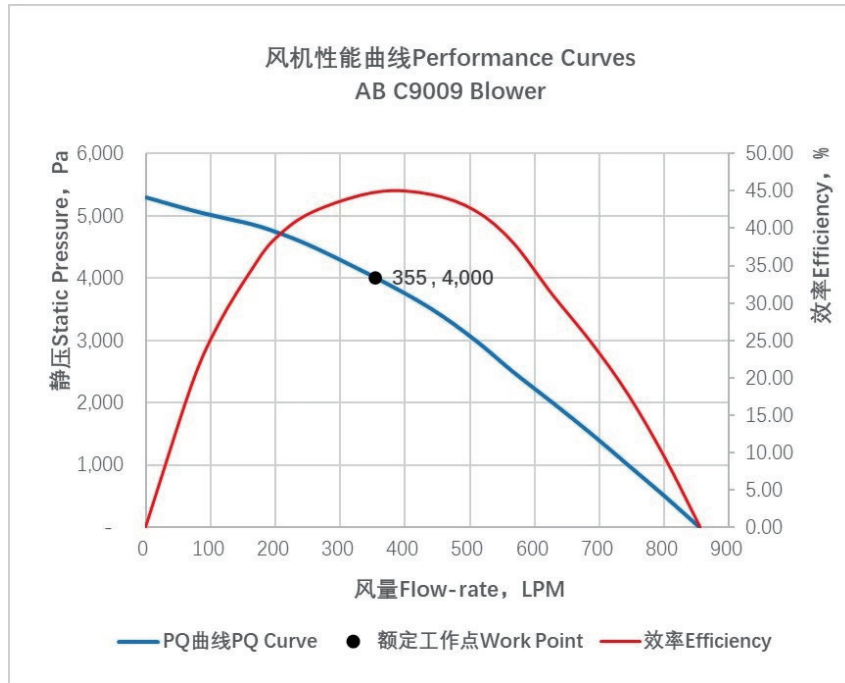

■ INTERFACE DRAWING

C90-1/C90-2 Series

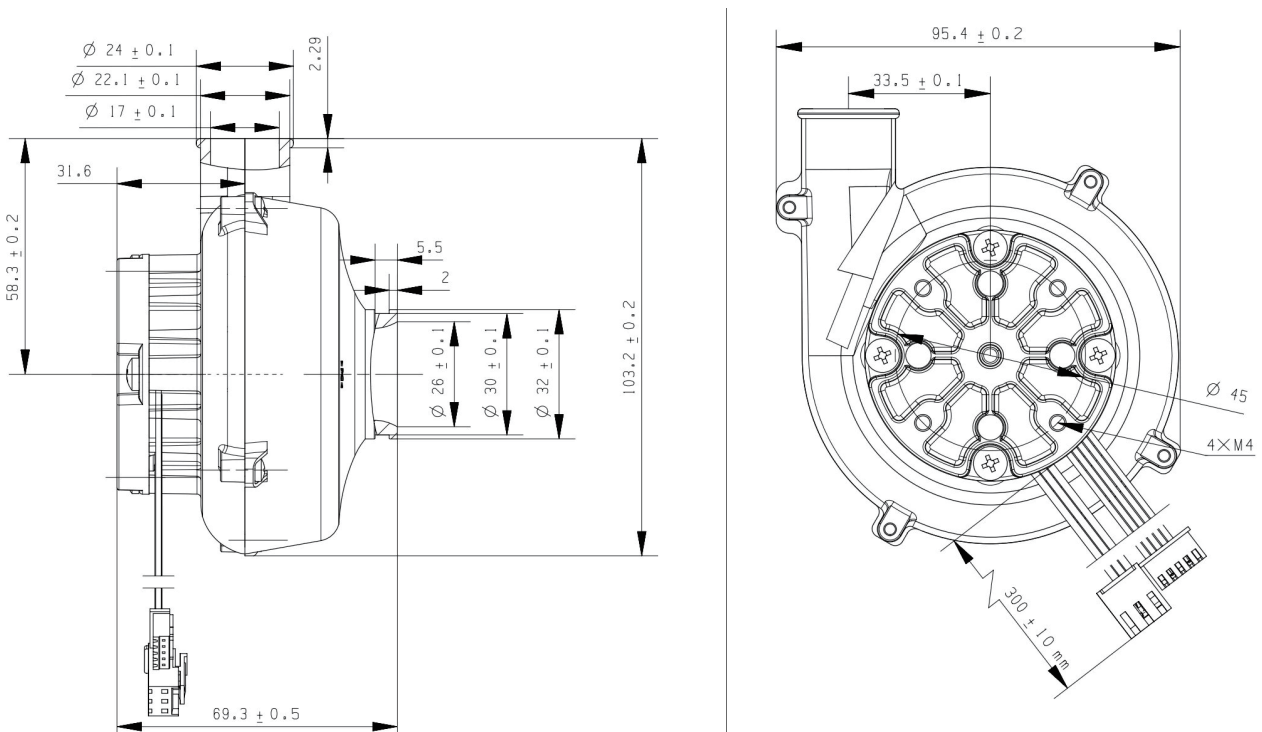

Series Name

C90

Motor Simplified Name

C9010

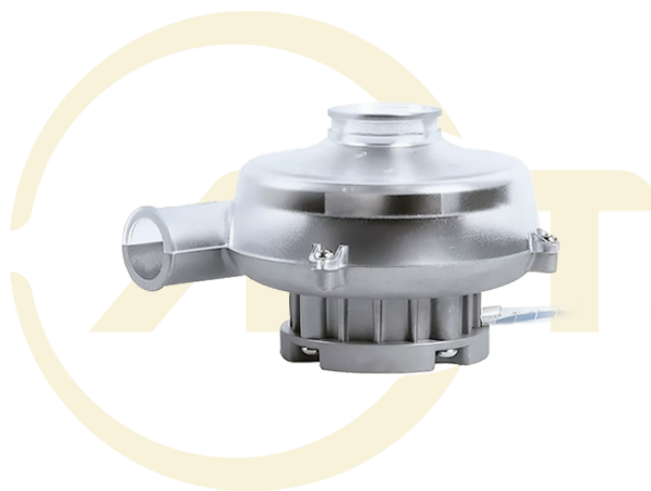

PRODUCT PARAMETERS

Item Name	C9010
Brand Name	ANCFLOW
Model Number	C9010-24V-1
Part Name	Brushless DC Blower
Rated Power (W)	50
Rated Voltage (V)	24
Power Supply Type	DC
Driver Layout	External
max.Static Pressure	5.0kPa
max.Flow Rate	872LPM (52.3m ³ /h)
Rated Static Pressure	4.0kPa
Rated Flow Rate	383LPM (23.0m ³ /h)
Temperature Range(ambient)	-20°C~+50°C
Humidity Range(ambient)	≤85%RH
Size	103.2*95.4*69.3mm
Service life (L10 at 40)	20,000h
Certification	RoHS, CE
Application Field	medical smoke removal equipment, ventilator, hydrogen fuel cell, cold chain sterilization equipment, disinfection and sterilization equipment, oxygen generator, dental equipment, negative pressure isolation chamber, PARR, moxibustion smoking, household fresh air system, temperature and humidity control, environmental monitoring equipment, gas detector, air cushion aerator, glove box, industrial smoke/dust removal equipment, liquid atomization, cooling and drying equipment, agricultural machinery, fishery aerator, etc.

■ PERFORMANCE CURVES

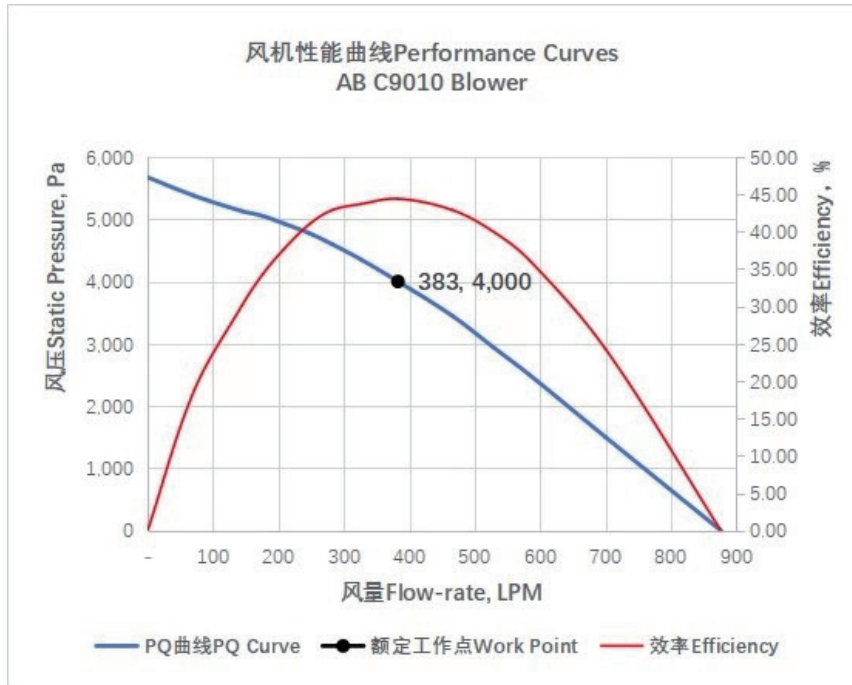

■ INTERFACE DRAWING

C90-1/C90-2 Series

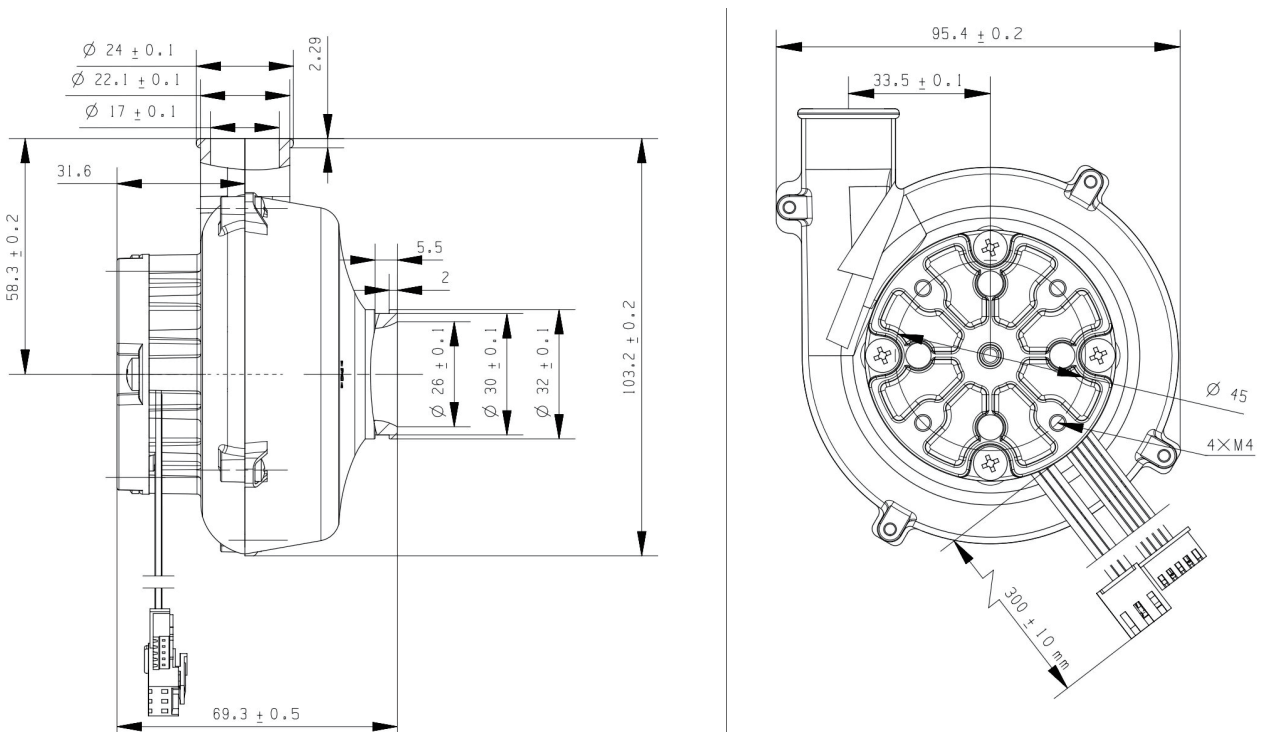

Series Name

S80

Motor Simplified Name

S8001-24V-1



PRODUCT PARAMETERS

Item Name	S8001-24V-1
Brand Name	ANCFLOW
Model Number	S8001-24V-1
Part Name	Brushless DC Blower
Rated Power (W)	185
Rated Voltage (V)	24
Power Supply Type	DC
Driver Layout	Integrated
max.Static Pressure	17.0kPa
max.Flow Rate	1,000LPM (60.0m ³ /h)
Rated Static Pressure	13.0kPa
Rated Flow Rate	430LPM (25.8m ³ /h)
Temperature Range(ambient)	-20°C~+50°C
Humidity Range(ambient)	≤85%RH
Size	85.3*82.2*82.0mm
Service life (L10 at 40)	20,000h
Certification	RoHS, CE
Application Field	medical smoke removal equipment, ventilator, hydrogen fuel cell, cold chain sterilization equipment, disinfection and sterilization equipment, oxygen generator, dental equipment, negative pressure isolation chamber, PARR, moxibustion smoking, household fresh air system, temperature and humidity control, environmental monitoring equipment, gas detector, air cushion aerator, glove box, industrial smoke/dust removal equipment, liquid atomization, cooling and drying equipment, agricultural machinery, fishery aerator, etc.

■ PERFORMANCE CURVES

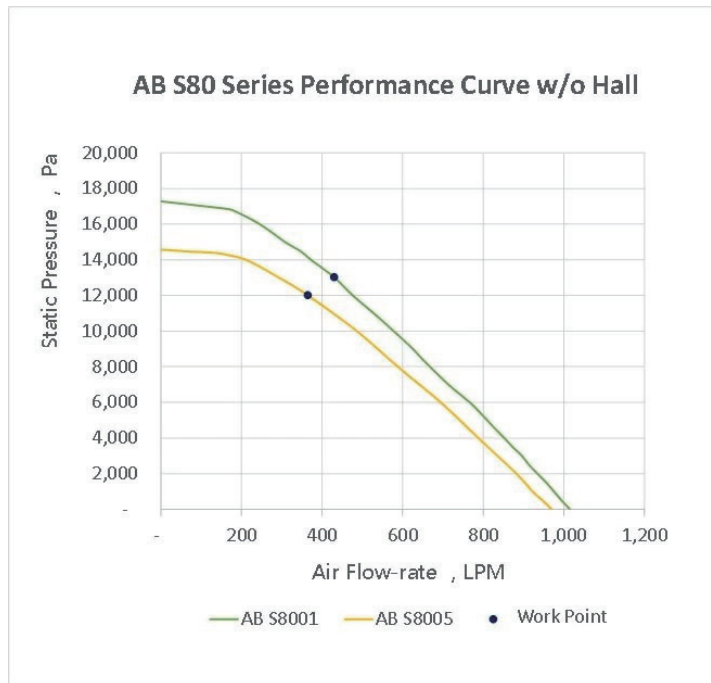

■ INTERFACE DRAWING

S80 Series

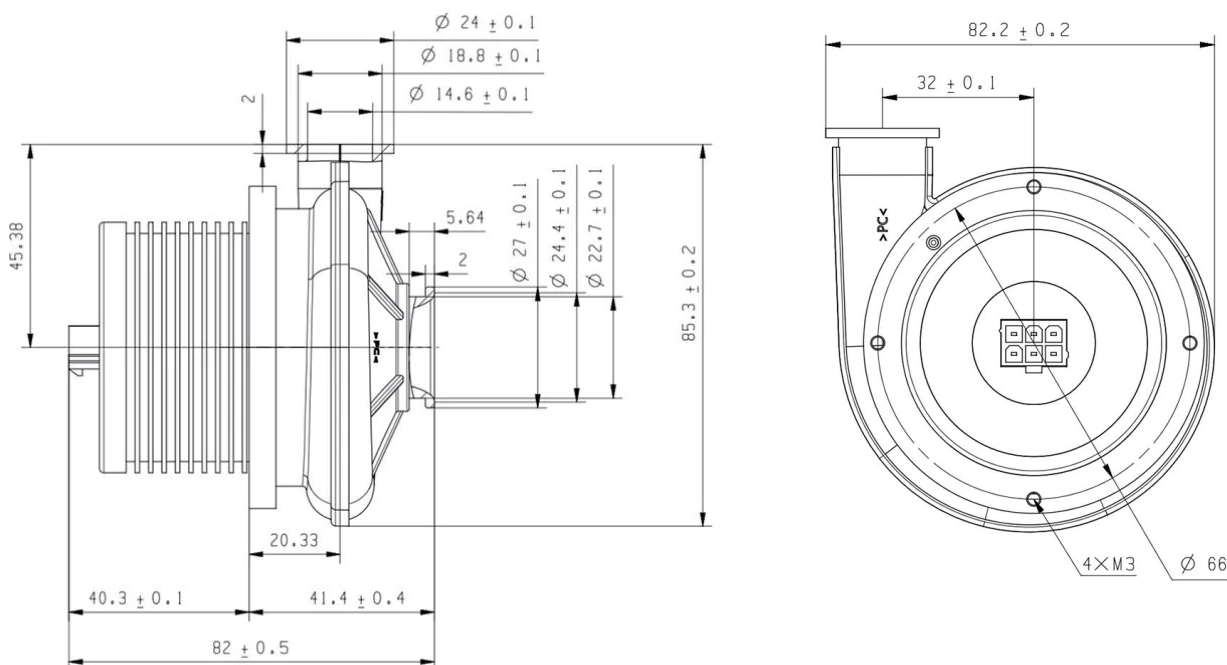

Blower Accessories

The Drawings of Inlet/Outlet Extension Pipes

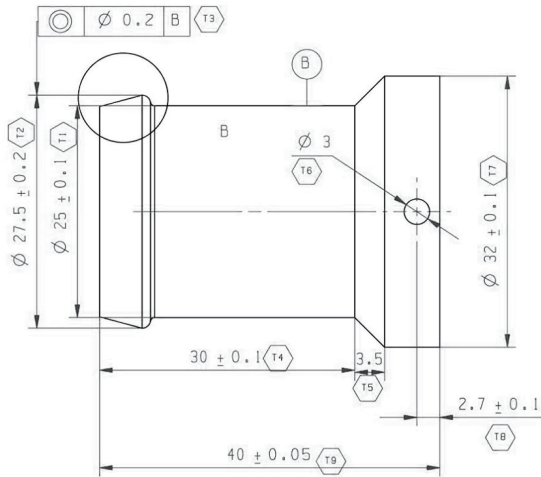

▪ Inlet Extension Pipe- S80/C80 Series

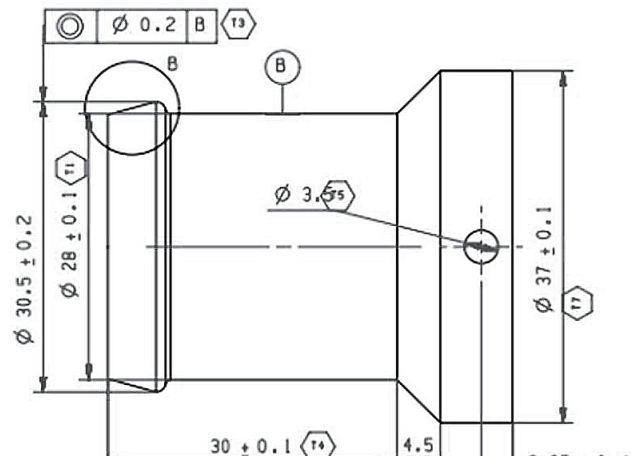

▪ Outlet Extension Pipe- S80/C80 Series

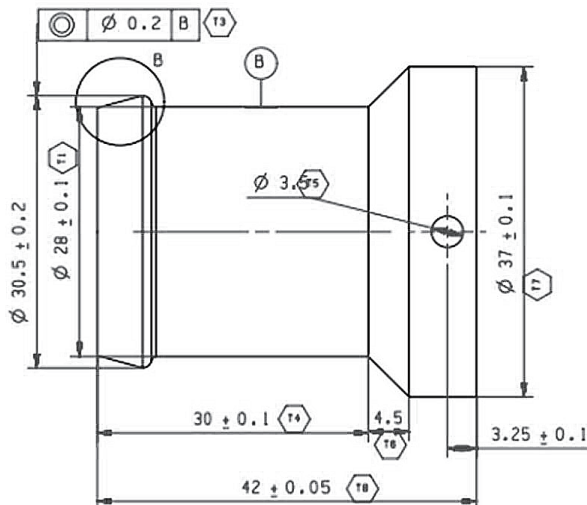

▪ Inlet Extension Pipe- C90 Series

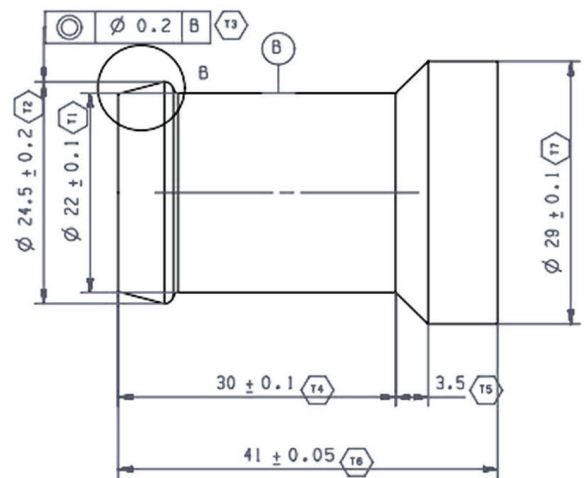

▪ Outlet Extension Pipe- C90 Series

Certificates

CE Certificates



ISO9001 CE Certificates QS Certificates



RoHS Certificates



ISO 10993 Test Report



REACH Certificates

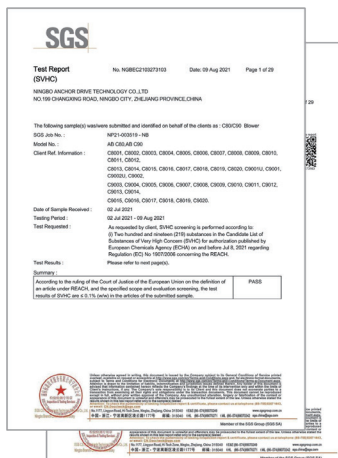

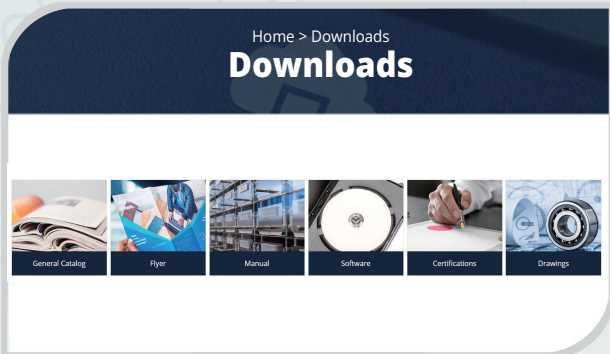
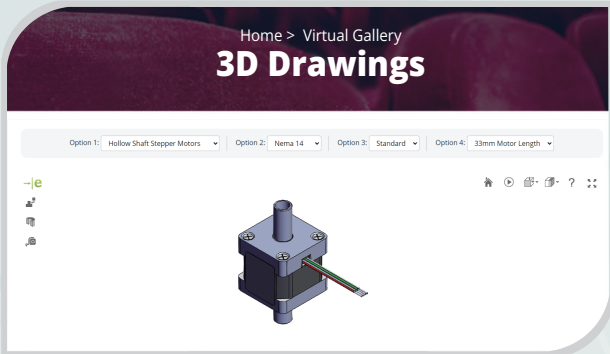
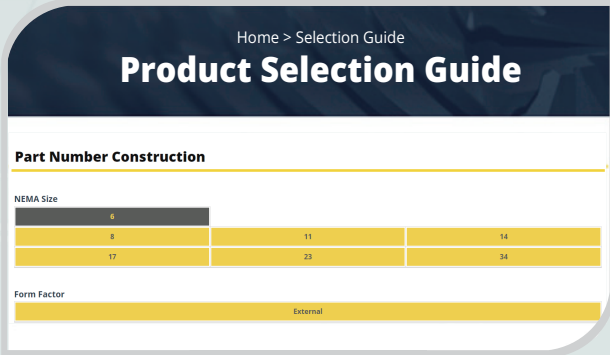

DINGS^Y

Precision Motion Specialist

Headquarter , CHINA

Jiangsu DINGS' Intelligent Control Technology Co., LTD

No. 2850 Luheng Road, Changzhou Economic Development Zone, Jiangsu Province, China

Phone : +86-519-85177826

Fax : +86-519-85177807

E-mail : info@dingsmotion.com

www.dingsmotion.com

Shenzhen Office

Room 1105, Block C, CIMC industry demonstration park, Qiaoming Road, Guangming district, Shenzhen City

E-mail : info@dingsmotion.com

International Office

DINGS' Motion USA

355 Cochrane Circle Morgan Hill, CA 95037

Phone : +1-408-612-4970

E-mail : sales@dingsmotionusa.com

www.dingsmotionusa.com

DINGS' JAPAN

101, 2-27-18, Nishi-kojiya, Ota-ku, Tokyo 144-0034 JAPAN

Phone : +81-90-7730-0034

E-mail : tsukahara@dingsmotion.com



Floor 1&2, Building 5, No.1 Zidan Road, Nanjing, Jiangsu, China 210002

Phone : +86 139 6834 9384

E-mail : carly.ying@anchor-drive.com

www.anchor-drive.com



C-702, 158, Haneulmaeul-ro, Ilsandong-gu, Goyang-si, Gyeonggi-do, Republic of Korea

Phone : 031-994-0755

E-mail : daniel@dingsmotion.com

DINGS' KOREA CO., Ltd.
ADT Official Distributor In Korea

www.dingsmotion.kr