



VER 1.2

# Technical Manual

## DS-OLS2-FPD Digital Stepping Driver



SW8 SW7 SW6 SW5 SW4 SW3 SW2 SW1 RS232 PWR/ALM

**DINGS** 鼎智  
www.dingsmotion.com

**DS-OLS2-FPD**

Current Table				Pulse/rev Table			
Peak	SW1	SW2	SW3	Mstep	SW4	SW5	SW6
0.3A	on	on	on	200	on	on	on
0.5A	off	on	on	400	off	on	on
0.7A	on	off	on	800	on	off	on
1.0A	off	off	on	1600	off	off	on
1.3A	on	on	off	3200	on	on	off
1.6A	off	on	off	6400	off	on	off
1.9A	on	off	off	12800	on	off	off
2.2A	off	off	off	25600	off	off	off

ALM LED Codes  
 ALM RD Times  
 Over current 1  
 Over voltage 2

SW7: Pulse Mode  
 off=PUL/DIR,  
 on=CW/CCW

SW8: Self Test  
 off=Disable  
 on=Enable

VDC: +18V~+36V Control Signal: 5V

PUL+  
 PUL-  
 DIR+  
 DIR-  
 ENA+  
 ENA-  
 ALM+  
 ALM-  
 GND  
 +Vdc  
 A+  
 A-  
 B+  
 B-

# Table of Contents

1. Introduction.....	3
1.1 Features.....	3
1.2 Technical Parameters.....	3
1.3 Dimensional Drawing (mm).....	4
2. Schematic Diagram and Interface Definition.....	5
3. Set Switch.....	6
3.1 Subdivision Setting.....	6
3.2 Operation Mode.....	6
3.3 Current Setting.....	7
3.4 Indicator Light Function.....	7
4. Power Supply.....	8
4.1 Voltage.....	8
4.2 Current.....	8
4.3 Regeneration of Discharge.....	8
5. Motor Connection.....	9
6. Signal Input.....	10
6.1 Pulse Signal : PUL.....	10
6.2 Direction Signal : DIR.....	10
6.3 Pulse / Direction Input Timing Diagram.....	11
6.4 Offline Signal : ENA.....	11
7. Typical Signal Connection Method.....	12
7.1 Differential Connection Method.....	12
7.2 Co Positive Connection Method.....	12
7.3 Co Negative Connection Method.....	12
8. Wiring Requirements.....	14

# 1. Introduction

## 1.1 Features

- Input power supply : DC 24V~36V
- 8 level current selection and 8 level subdivision selection
- Single / dual pulse selection
- Capable of automatic detection
- PWM constant current bipolar subdivision drive
- Photoelectric isolation input function
- Motor short circuit protection function
- Exquisite design, low noise, and low vibration

## 1.2 Technical Parameters

Drive model		DS-OLS2-FPD
Adapter motor		Adapted to two-phase hybrid stepping motor, DS-OLS2-FPD Maximum adaptation 2.2A
Power supply		24 - 36V DC
Output current		DS-OLS2-FPD : 0.3A-2.2A/ phase (peak)
Drive mode		Full-bridge bipolar PWM driver
Input signal	Pulse signal	Optocoupler input voltage H = 3.5 - 26.0V , L = 0 - 0.8V On current 6-15mA
	Direction signal	
	Offline signal	
Output signal	Alarm signal	Optically isolated output, highest withstand voltage 30VDC , Maximum saturation current 50mA
Size (excluding terminals)		86 × 21 × 55mm
Weight (excluding terminals)		About 90 g
Use surroundings	Use occasion	Avoid dust, oil mist and corrosive gases
	Humidity	< 85 % RH, No condensation
	Temperature	0°C - +40°C
	Heat dissipation	Installed in a ventilated environment

### 1.3 Dimensional Drawing (mm)

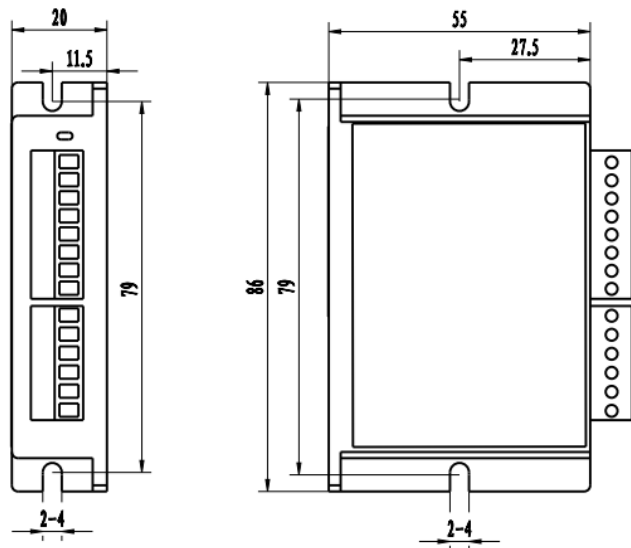

#### Drive installation

Install with narrow edges and M4 screws through the holes on both sides. The power device of the driver will generate heat. If it operates continuously under high input voltage and high power conditions, the effective heat dissipation area should be expanded or forced cooling should be applied.

Do not use in areas where the air is not circulating or where the ambient temperature exceeds 40 °C

Do not install the drive in damp or metal shavings.

## 2. Schematic Diagram and Interface Definition

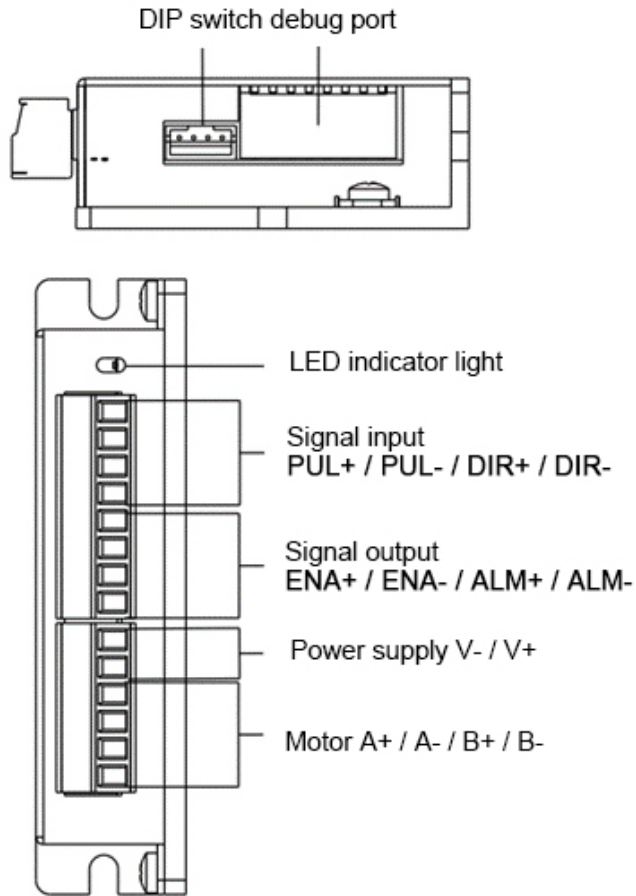

### 3. Set Switch

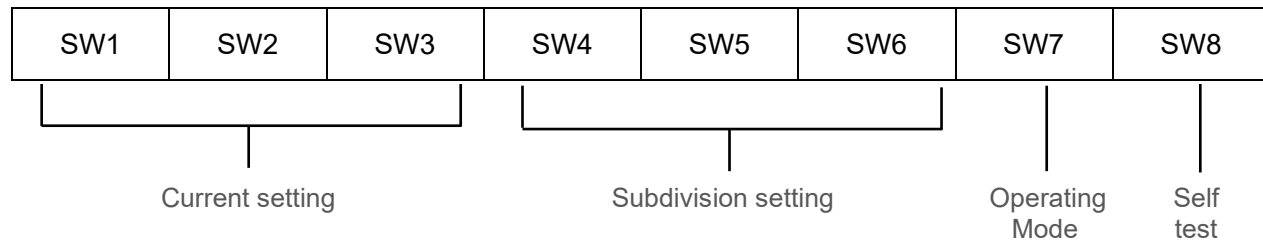

#### 3.1 Subdivision Setting

DIP switch			Pulse count / Revolution
SW4	SW5	SW6	
ON	ON	ON	200
OFF	ON	ON	400
ON	OFF	ON	800
OFF	OFF	ON	1600
ON	ON	OFF	3200
OFF	ON	OFF	6400
ON	OFF	OFF	12800
OFF	OFF	OFF	25600

#### 3.2 Operation Mode

SW7	Operation mode
ON	Double pulse
OFF	Pulse + direction

Pulse+Direction Mode : Pulse is added to the pulse input end. When the optocoupler at the direction input end is not connected, the motor rotates in one direction, and when the optocoupler at the direction input end is connected, the motor rotates in the other direction

Dual Pulse Mode : When the pulse input terminal is pulsed, the motor rotates in one direction, and when the direction input terminal is pulsed, the motor rotates in the other direction.

#### Self inspection function

Self Test Trigger Condition : The trial run function is used to verify the performance of the drive. Set SW8 to ON in the power off state to activate the trial operation function (the motor rotates forward and backward at a speed of 1 rpm). SW8 is set to the OFF position, and the self check function is turned off.

### 3.3 Current Setting

DIP switch			DS-OLS2-FPD Phase current (peak)
SW1	SW2	SW3	
ON	ON	ON	0.3A
OFF	ON	ON	0.5A
ON	OFF	ON	0.7A
OFF	OFF	ON	1.0A
ON	ON	OFF	1.3A
OFF	ON	OFF	1.6A
ON	OFF	OFF	1.9A
OFF	OFF	OFF	2.2A

### 3.4 Indicator Light Function

This product has two LED indicators in red and green to display the status:

#### Status indication:

Status function	Green light	Explain
Stopping	Flashing	Enable, motor phase locked but motor not running
Running	Always on	Drive is running
Enable disconnection	Flashing	Enable disconnection, motor can be free

#### Fault indication:

Alarm function	Light Flashing	Explain
Motor overcurrent	1 green+1 red	Motor phase current overcurrent or driver failure
Motor phase loss	1 green+2 red	The motor is not connected
Overvoltage	1 green+3 red	Power input greater than 40V
Undervoltage	1 green+4 red	Power input less than 15V
Other alarms	1 green+5 red	

## 4. Power Supply

### 4.1 Voltage

The chopper driver continuously changes the magnitude and direction of the motor winding terminal voltage during operation, while detecting the current to obtain accurate phase current. If both high efficiency and low noise are to be ensured, the driver supply voltage should be at least 5 times the rated phase voltage of the motor (the rated phase current of the motor  $\times$  Phase resistance).

If you need the motor to achieve better high-speed performance, you need to increase the driver supply voltage. If using a regulated power supply, it is required that the power supply voltage should not exceed 36V. If using a non regulated power supply, the voltage must not exceed 25V.

Because the rated current of non regulated power supply is full load current. When the load is very light, such as when the motor is not running, the actual voltage can reach 1.4 times the rated voltage of the power supply. If you want the motor to run smoothly and quietly, choose low voltage.

### 4.2 Current

The maximum power supply current should be the sum of the two phase currents. Usually, the current you need depends on the motor model, voltage, speed, and load conditions. The actual power supply current value is significantly lower than this maximum current value because the driver uses a switching amplifier to convert high voltage and low current into low voltage and high current. The more the power supply voltage exceeds the motor voltage, the less power supply current is required.

### 4.3 Regenerative Discharge

When the motor slows down, it converts the kinetic energy of the load into electrical energy like a generator. Some energy will be consumed by the driver and motor. If your application has a large load running at high speed, a considerable amount of kinetic energy will be converted into electrical energy. It is easy to cause driver alarms (overvoltage) and may even cause damage to the driver.



## 5. Motor Connection



### Caution

When connecting the motor to the drive, please confirm that the power supply to the drive is turned off first. Confirm that the unused motor leads are not shorted to other objects. During the power on period of the driver, the motor cannot be disconnected. Do not connect the motor leads to the ground or power supply.

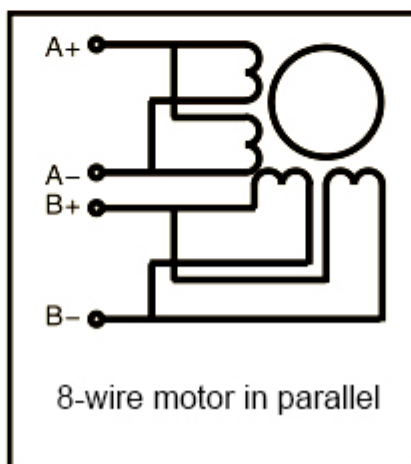
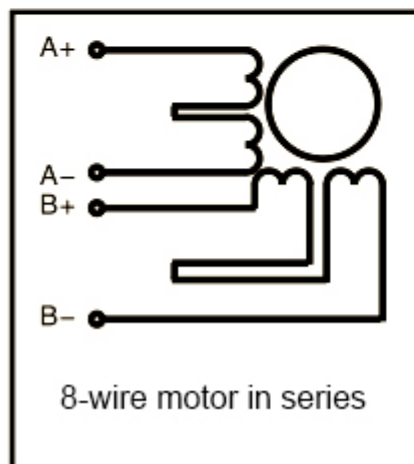
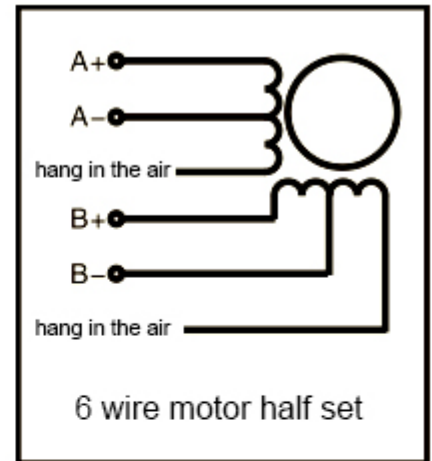
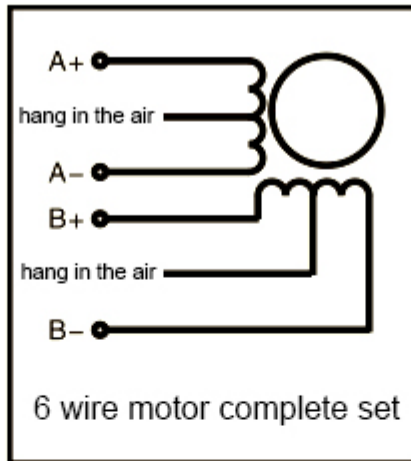
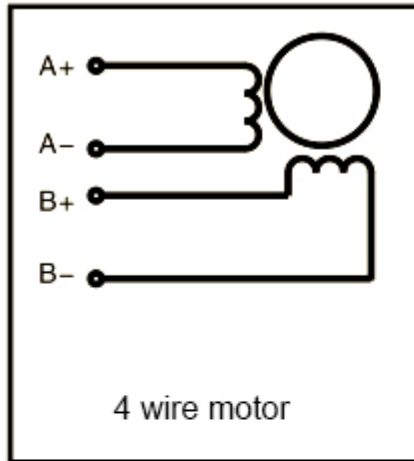

- 1) Four-wire motors can only be connected in one way.
- 2) Six-wire motors can be connected in two ways: full group and half group. In the full group mode, the motor has greater torque at low speeds, but it cannot run as fast as in the half group. When the whole group is running, the motor needs to run at less than 30% of the half-group current to avoid overheating.
- 3) Eight-wire motors can be connected in two ways: series and parallel. The series mode has greater torque at low speeds and less torque at high speeds. When running in series, the motor needs to run at 50% of the current in parallel to avoid overheating.



## Notes

- 1) The corresponding colors of different motors are different. When using the motors, the specifications of the motors shall prevail.
- 2) The phases are relative, but the windings of different phases cannot be connected to the terminals of the same phase of the driver (A +, A- is one phase, B +, B- is the other phase). If the motor direction is different from the expected direction, only A + , A-.
- 3) This driver can only drive two-phase hybrid stepping motors, not three-phase and five-phase stepping motors.

## 6. Signal Input

### 6.1 Pulse Signal : PUL

Can accept 5VDC single ended or differential signals. The change from off to on is understood as receiving an effective pulse along the instruction. For the common anode, the low level is effective (for the common cathode, the high level is effective), and at this time, the driver will drive the motor to run one step according to the corresponding timing. For the normal operation of the driver, the duty cycle of the effective level signal should be below 50%. To ensure the reliable response of the pulse signal, the duration of the pulse effective level of the subdivided driver should not be less than 2.5us. The signal response frequency of the subdivision driver is 200KHz, and an excessively high input frequency may result in incorrect response.

### 6.2 Direction Signal : DIR

Can accept 5VDC single ended or differential signals. The on and off of the internal optocoupler at this end are interpreted as two directions of motor operation, and a change in the direction signal will cause a change in the direction of motor operation. The suspension at this end is equivalent to an input high level. It should be noted that the subdivision driver should ensure that the direction signal is established at least 10us ahead of the pulse signal input to avoid incorrect response of the driver to the pulse signal. When reversing the motor, it is necessary to slow down the motor to the starting frequency before reversing. The commutation signal must change after the end of the last PUL pulse of the previous direction signal and before the first PUL pulse of the next direction signal. When there is no need to change direction, the direction signal end can be suspended.

### 6.3 Pulse / Direction Input Timing Diagram

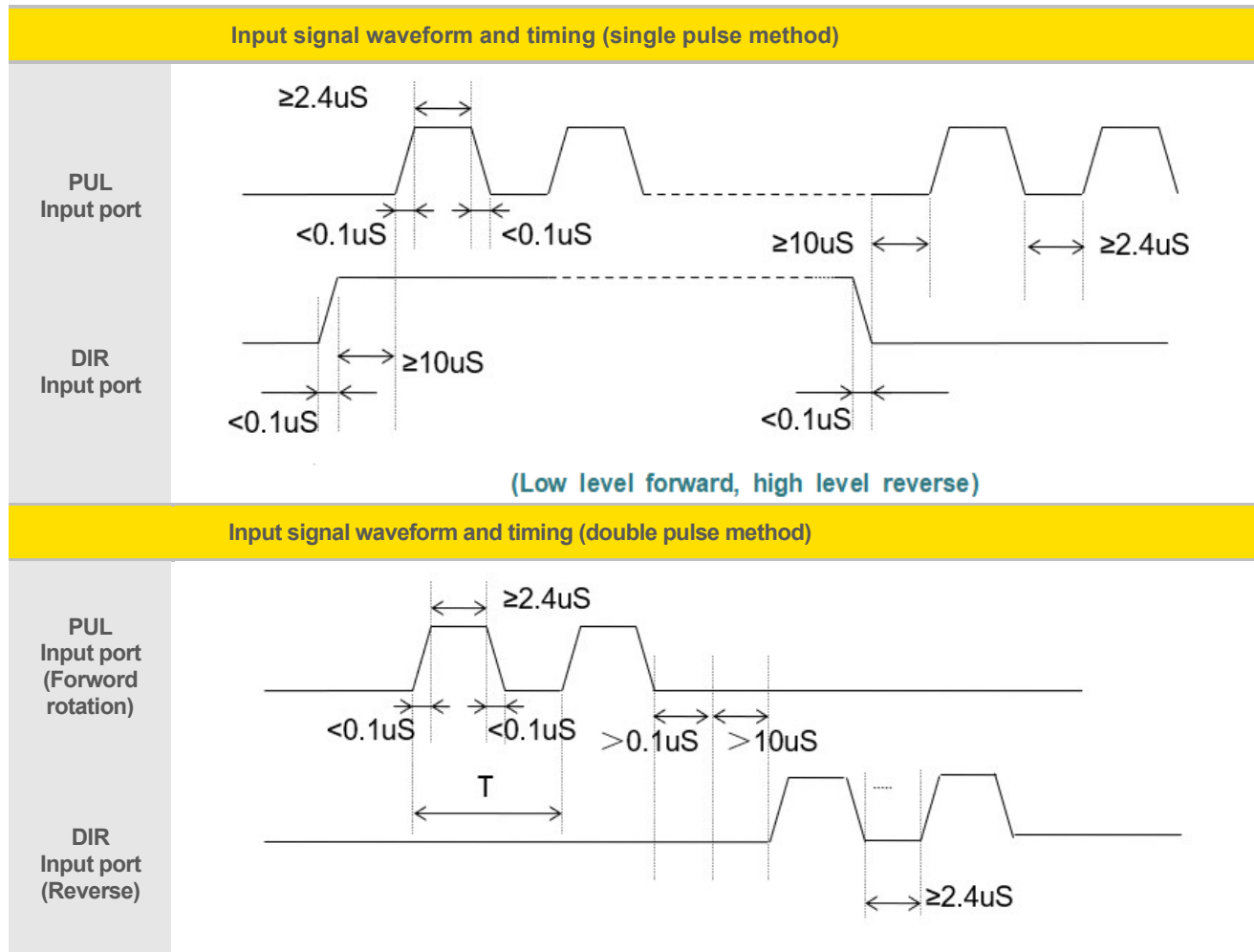

### 6.4 Offline Signal : ENA

Can accept 5VDC single ended or differential signals. When the built-in optocoupler is turned on, the motor phase current is cut off and the rotor is in a free state (offline state). When this function is not needed, the offline signal end can be suspended.

## 7. Typical Signal Connection Method

### 7.1 Differential Connection Method

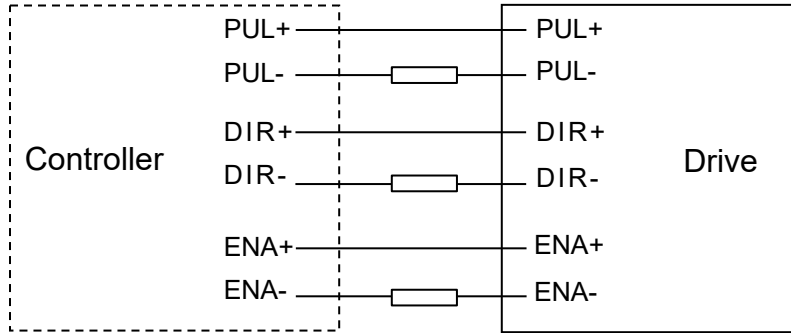

### 7.2 Co Positive Connection Method

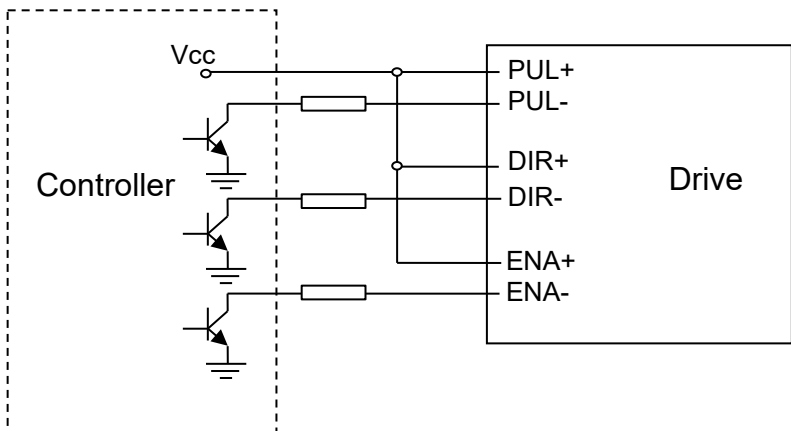

### 7.3 Co Negative Connection Method

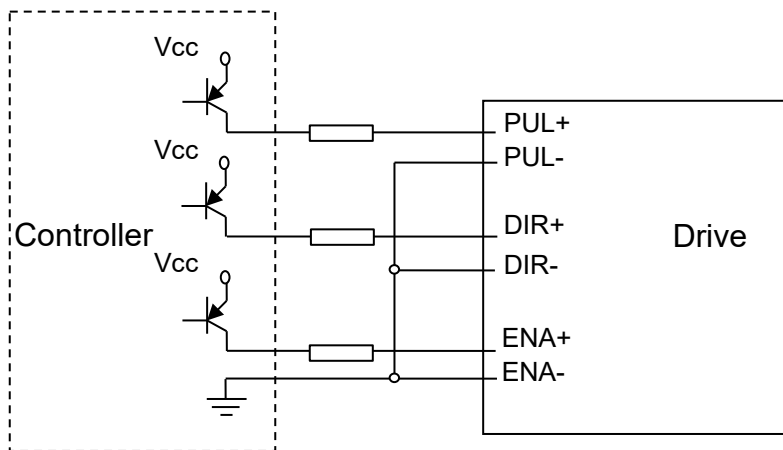

**Notes**

VCC 3.5-5 VDC R=0 Ω VCC 12VDC R=1K Ω  
VCC 24VDC R=2.2K Ω

## Typical Connection Method for Signal Output

### Relay Connection

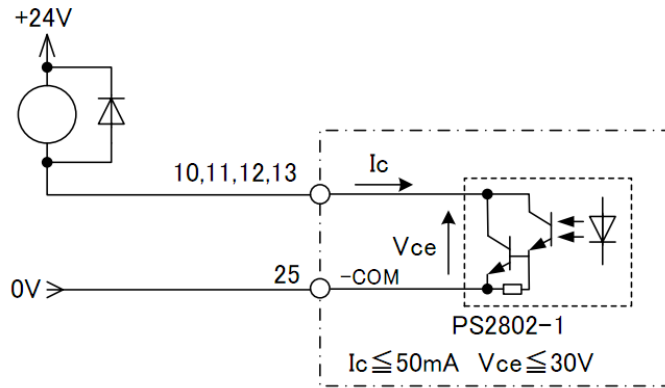

**Notes** When the relay is connected, it is required to connect diodes at both ends of the relay (such as IN4000 series)

### Optocoupler Connection

The alarm output is photoelectric isolation, with a maximum withstand voltage of 30VDC and a maximum saturation current of 50mA.

When the driver is working properly, the output is closed.

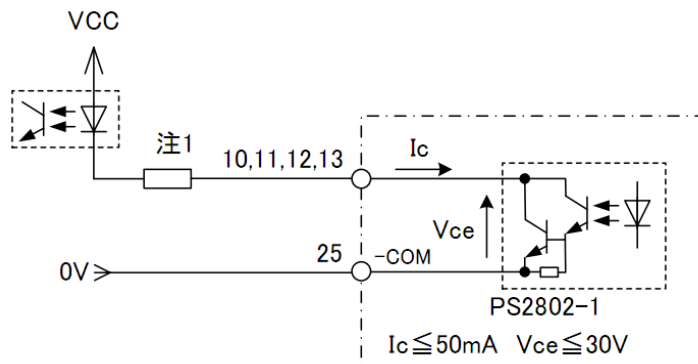

When the driver makes an error, the output is suspended.

## 8. Wiring Requirements

- 1) In order to prevent the driver from being disturbed, it is recommended to use shielded cable for the control signal, and the shield layer should be shorted to the ground. Except for special requirements, the shielded wire of the control signal cable is grounded at one end: the upper end of the shielded cable is grounded. The driver end of the wire is left floating. Grounding can only be performed at the same point in the same machine. If it is not a real ground wire, the interference may be serious, and the shielding layer is not connected at this time.
- 2) Pulse and direction signal lines and motor lines are not allowed to be bundled side by side, preferably at least 10cm apart, otherwise motor noise may easily interfere with pulse direction signals, causing inaccurate positioning of the motor, system instability and other faults.
- 3) If one power supply is used for multiple drives, a parallel connection should be adopted at the power supply. It is not allowed to connect one to the other in a chain.
- 4) It is strictly forbidden to plug and unplug the driver's strong current (motor and power) terminals. When the charged motor is stopped, a large current still flows through the coil. Plugging and unplugging the strong current (motor and power) terminals will cause a huge momentary induced electromotive force to burn out driver.
- 5) It is strictly forbidden to add lead to the terminal after adding tin, otherwise the terminal may be damaged due to overheating due to the increased contact resistance.
- 6) The wiring head must not be exposed outside the terminal to prevent the driver from being accidentally shorted.



+86-0519-8517 7825



+86-0519-8517 7807



No. 2850 Luheng Road, Changzhou Economic Development Zone, Jiangsu Province, China



[www.dingsmotion.com](http://www.dingsmotion.com)

### International Customer

Person in Charge :

*Daniel Jang*

[daniel@dingsmotion.com](mailto:daniel@dingsmotion.com)

No. 2850 Luheng Road, Changzhou  
Economic Development Zone,  
Jiangsu Province, China

+86-519-85177825, 85177826

### North America Customer

Person in Charge :

*Nicolas Ha*

[sales@dingsmotionusa.com](mailto:sales@dingsmotionusa.com)

335 Cochrane Circle Morgan Hill,  
CA 95037

+1-408-612-4970

### China Customer

Person in Charge :

*Sweet Shi*

[info@dingsmotion.com](mailto:info@dingsmotion.com)

No. 2850 Luheng Road, Changzhou  
Economic Development Zone,  
Jiangsu Province, China

+86-519-85177825, 85177826