

1

2

3

4

5

6

7

8

CHANGE

Revision

Date

Description

Approval

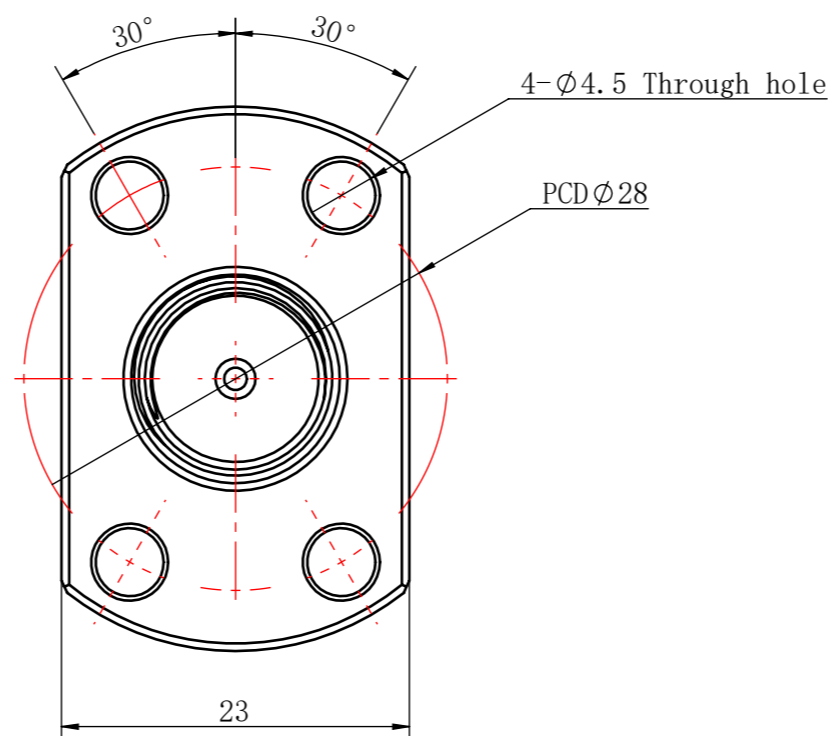
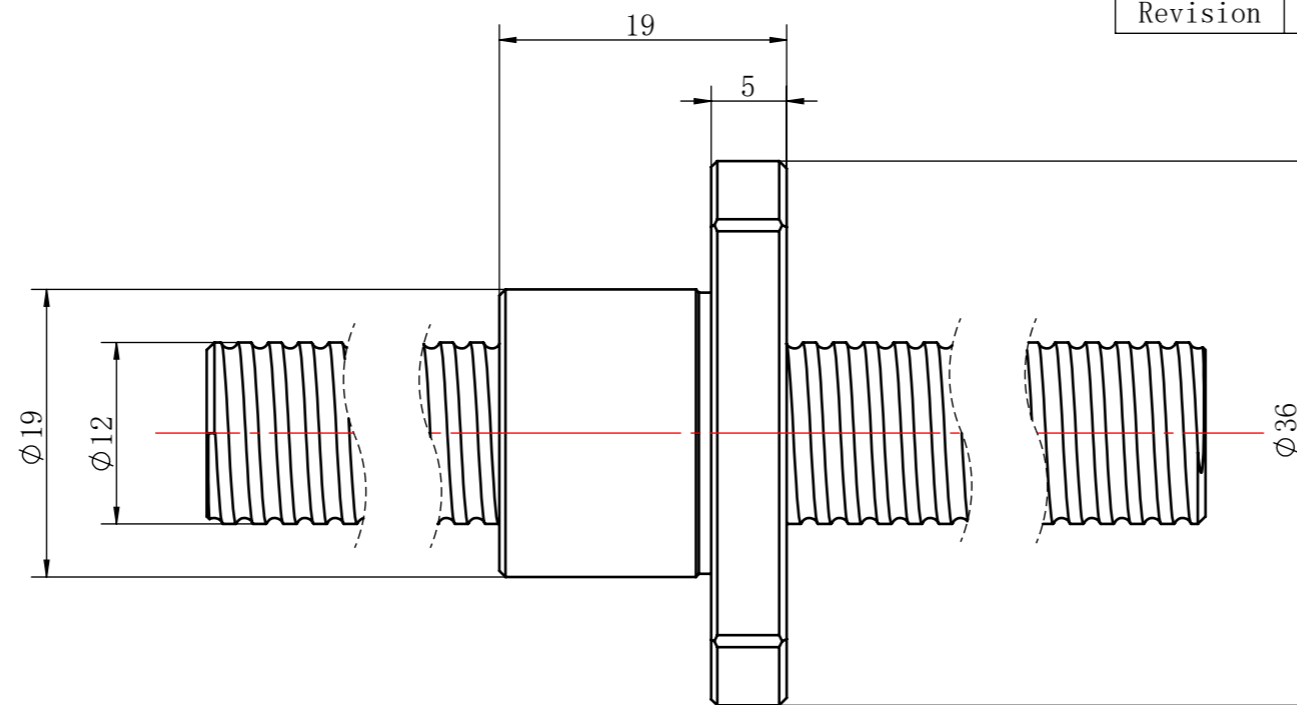

LINEAR		SPECIFICATION				CUSTOMER		
0.5~3	±0.1	B. C. D	Ø12.4	BALL SIZE	Ø1.2	C. MODLE		
>3~6	±0.1	SPACER BALL		LEAD	2	MODLE FBG1202		
>6~30	±0.2	ALLOW ROTATION NUMBER		LEAD ANGLE		NAME BALL SCREW		
>30~120	±0.3	LUBRICANT		NUMBER OF TURNSxROWS		WEIGHT		
>120~400	±0.5	O. C.	MAX. AXIAL Ca	THREAD DIRECTION/NUMBER OF THREAD		DESIGN		
>400~1000	±0.8		MAX. RPM	DYNAMIC Ca (N)		CHECK		
>1000~2000	±1.2	L. A.		STATIC Coa (N)		REV.		
ANGULAR				TRAVEL ERROR	PRELORD TORQUE		SCALE	
~10	±1°			LENGTH	AXIAL PLAY		TOTAL:	
>10~50	±30'				SCREW MATERIAL		PAGE:	
>50~120	±20'				NUT MATERIAL			
>120~400	±10'	ACCURACY GRADE:						

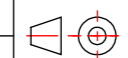

JIANGSU DINGS' INTELLIGENT CONTROL

1

2

3

4

5

6

7

8