

1

2

3

4

5

6

7

8

CHANGE

Revision

Date

Description

Approval

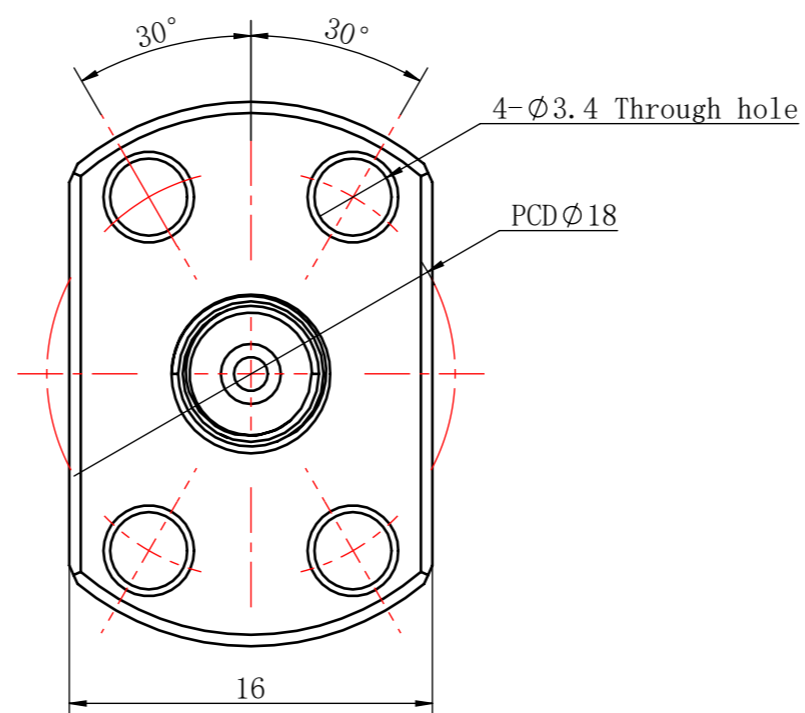
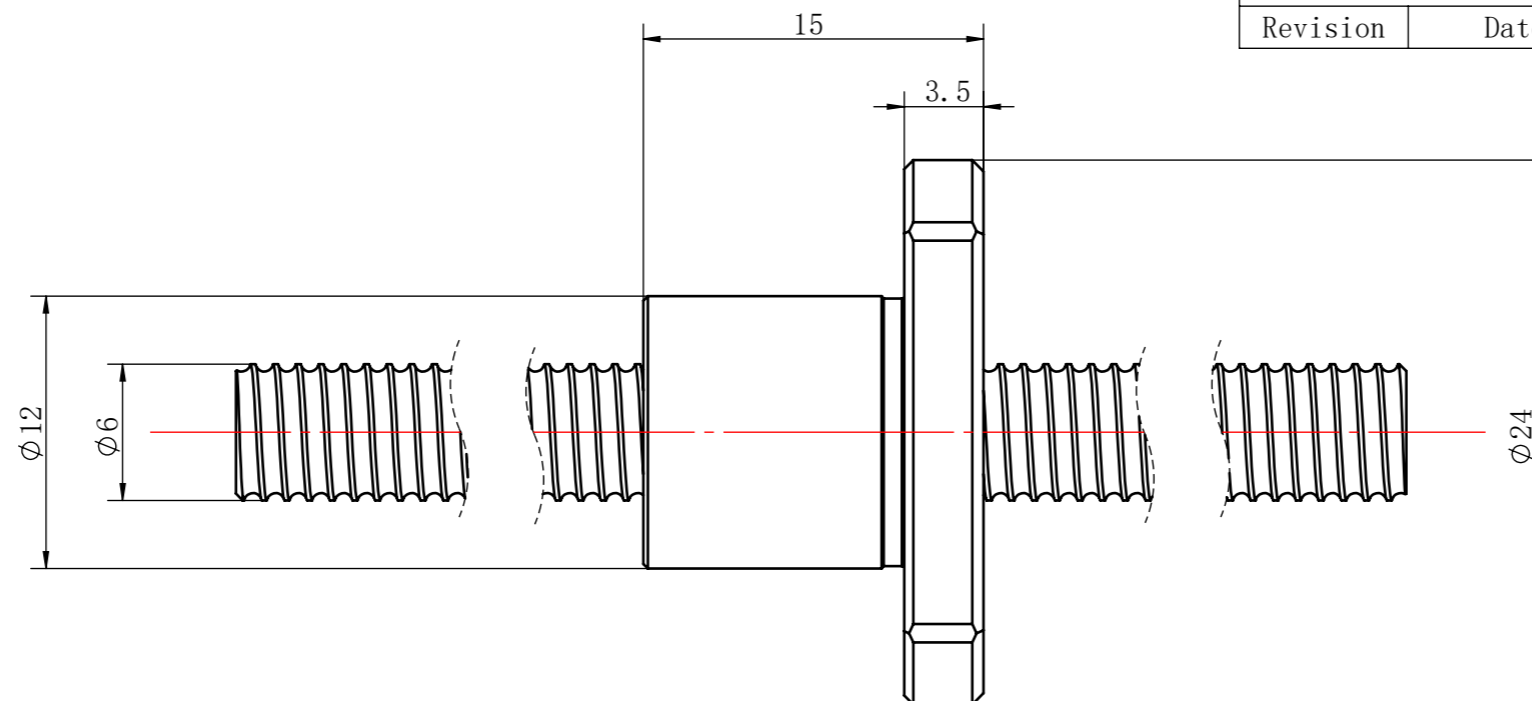

| LINEAR | | SPECIFICATION | | | | CUSTOMER | | |
|------------|------|-----------------------|---------------|-----------------------------------|----------------|------------------------------------|--------|--------|
| 0.5~3 | ±0.1 | B. C. D | Ø6.15 | BALL SIZE | Ø0.8 | C. MODLE | | |
| >3~6 | ±0.1 | SPACER BALL | | LEAD | 1 | MODLE FBG0601 | | |
| >6~30 | ±0.2 | ALLOW ROTATION NUMBER | | LEAD ANGLE | | NAME BALL SCREW | | |
| >30~120 | ±0.3 | LUBRICANT | | NUMBER OF TURNSxROWS | | WEIGHT | | |
| >120~400 | ±0.5 | O. C. | MAX. AXIAL Ca | THREAD DIRECTION/NUMBER OF THREAD | | SCALE | DESIGN | REV. |
| >400~1000 | ±0.8 | | MAX. RPM | | DYNAMIC Ca (N) | | CHECK | TOTAL: |
| >1000~2000 | ±1.2 | L. A. | | T ± ep | STATIC Coa (N) | UNITS | RATIFY | PAGE: |
| ANGULAR | | | | | PRELORD TORQUE | JIANGSU DINGS' INTELLIGENT CONTROL | | |
| ~10 | ±1° | | | | AXIAL PLAY | | | |
| >10~50 | ±30' | | | | SCREW MATERIAL | | | |
| >50~120 | ±20' | NUT MATERIAL | | | | | | |
| >120~400 | ±10' | ACCURACY GRADE: | | | | | | |

1

2

3

4

5

6

7

8