

1

2

3

4

5

6

7

8

CHANGE

Revision

Date

Description

Approval

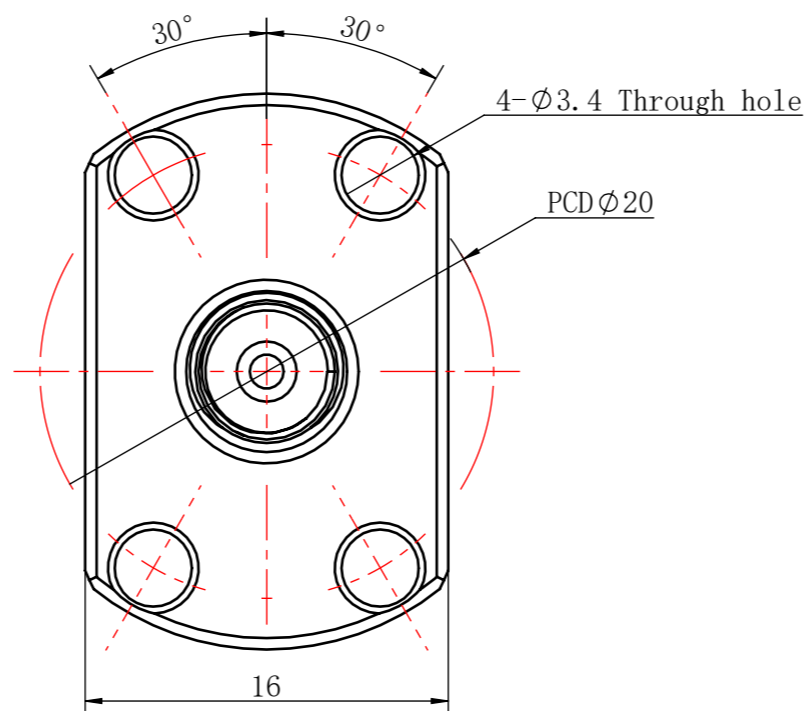
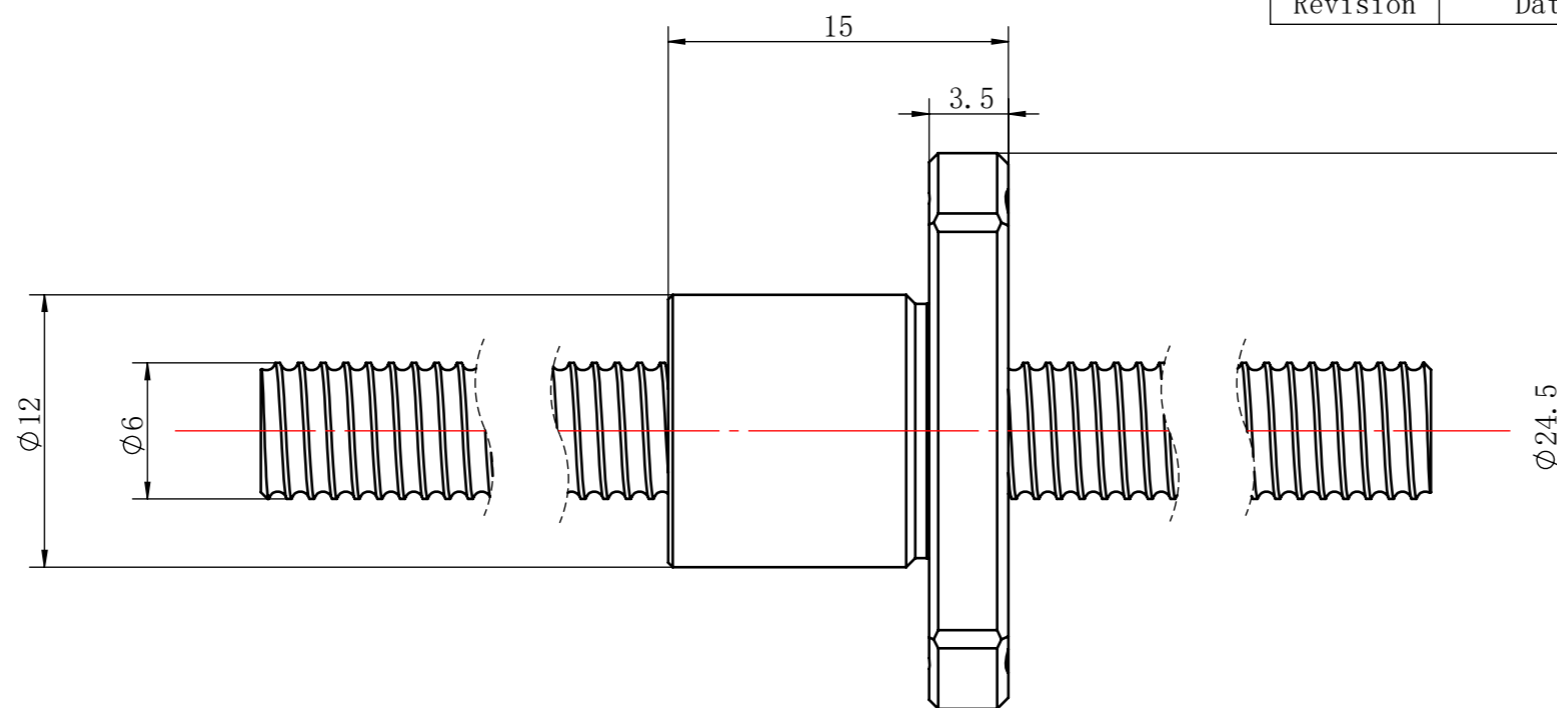

LINEAR		SPECIFICATION				CUSTOMER	
0.5~3	±0.1	B. C. D	Ø6.15	BALL SIZE	Ø0.8		
>3~6	±0.1	SPACER BALL		LEAD	1	C. MODLE	
>6~30	±0.2	ALLOW ROTATION NUMBER		LEAD ANGLE		MODLE FBG0601	
>30~120	±0.3	LUBRICANT		NUMBER OF TURNSxROWS		NAME BALL SCREW	
>120~400	±0.5	O. C.	MAX. AXIAL Ca	THREAD DIRECTION/NUMBER OF THREAD		WEIGHT	
>400~1000	±0.8		MAX. RPM	DYNAMIC Ca (N)		DESIGN	
>1000~2000	±1.2	L. A.		STATIC Coa (N)		SCALE	
ANGULAR				PRELORD TORQUE		CHECK	
~10	±1°			AXIAL PLAY		TOTAL:	
>10~50	±30'			SCREW MATERIAL		PAGE:	
>50~120	±20'			NUT MATERIAL			
>120~400	±10'	ACCURACY GRADE:		JIANGSU DINGS' INTELLIGENT CONTROL			

1

2

3

4

5

6

7

8