

| REVISION |      |             |          |
|----------|------|-------------|----------|
| REV.     | DATE | DESCRIPTION | DRAWN BY |
|          |      |             |          |

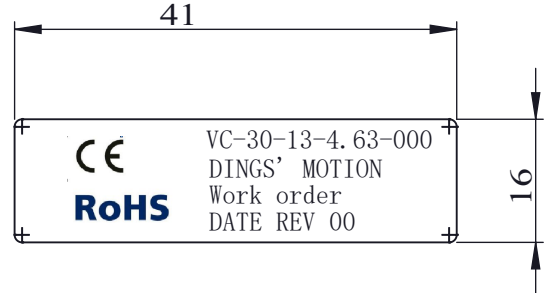
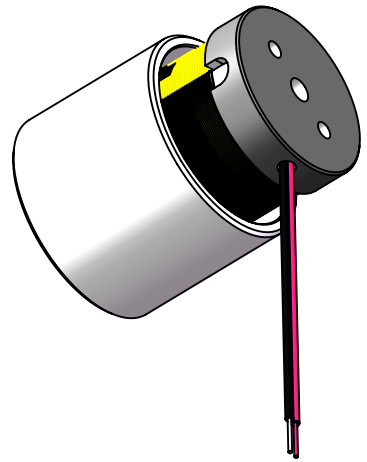
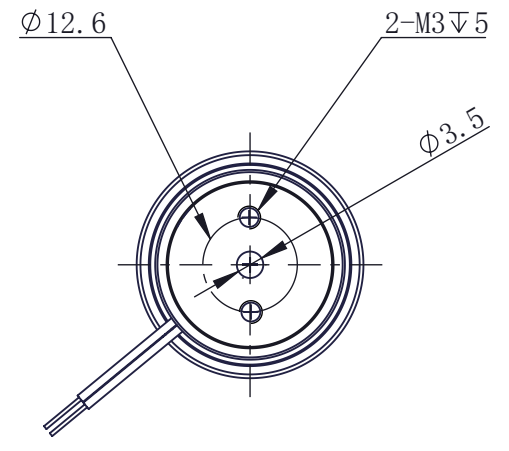
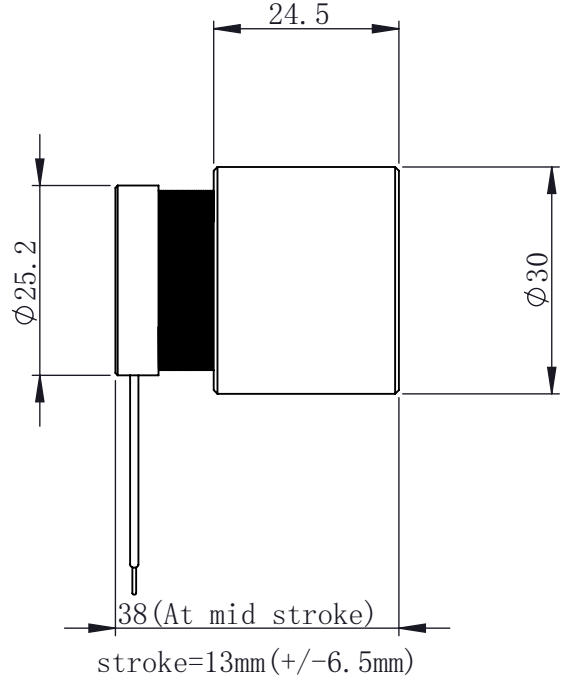
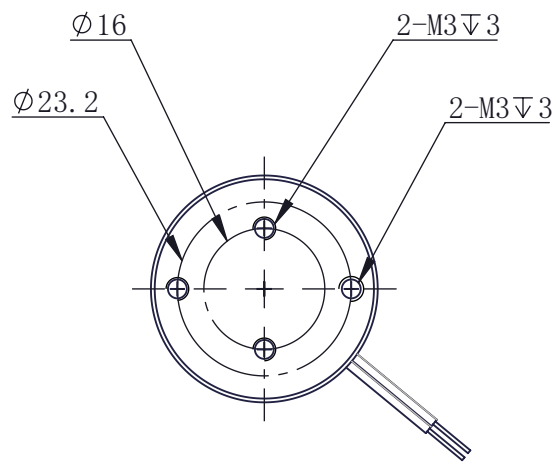

### TECHNICAL PARAMETERS

|   |          |                           |
|---|----------|---------------------------|
| Stroke (行程)                                 | mm       | 13                        |
| Continuous force (持续推力)                     | N        | 4.63                      |
| Peak force (最大推力)                           | N        | 29.4                      |
| Back EMF constant (反电动势常数)                  | V/m/s    | 7.35                      |
| Resistance (电阻)                             | $\Omega$ | $11.34 \pm 10\% \Omega$   |
| Inductance (电感)                             | mH       | $2.63 \pm 20\% \text{mH}$ |
| Continuous current (coil at 100 ° C) (持续电流) | A        | 0.63                      |
| Peak Current (最大电流)                         | A        | 4.3                       |
| Coil assembly mass (线圈重量)                   | g        | 25                        |
| Magnet mass (磁体重量)                          | g        | 96                        |
| Coil clearance (运动间隙)                       | mm       | 0.6                       |
| Insulation Class (绝缘等级)                     |          | B                         |

CUSTOMER



NOTICE TO PERSONS RECEIVING THIS DRAWING  
 THIS DRAWING IS ONLY CONDITIONALLY ISSUED, AND FOR THE SOLE PURPOSE OF INFORMING LICENSEES AND ASSOCIATE CONTRACTORS OF DINGS' MOTION, AND VENDORS THERETO AND CUSTOMERS THEREOF, RECEIPT OR POSSESSION THEREOF DOES NOT CONFER TO TRANSFER ANY RIGHT IN THE SUBJECT MATTER OF THE DRAWING. THE DESIGN, CONSTRUCTION, TECHNICAL INFORMATION AND ALL OTHER SUBJECT MATTER SHOWN IN THIS DRAWING ARE AND REMAIN, EXCEPT AS MAY BE OTHERWISE INDICATED BY WRITTEN NOTICE HEREON, THE EXCLUSIVE PROPERTY OF SAID CORPORATION. THIS DRAWING MAY BE REPRODUCED ONLY BY LICENSEES AND ASSOCIATE CONTRACTORS OF SAID CORPORATION AND ONLY FOR LICENSED MANUFACTURE, AND BY VENDORS MANUFACTURING FOR SAID CORPORATION AND ONLY FOR LICENSEES AND ASSOCIATE CONTRACTORS.

WIRING CHART

EXCITING SEQUENCE

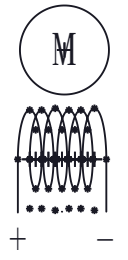

|         |   |   |
|---------|---|---|
| UP      | → |   |
| Red +   | + | - |
| Black - | - | + |
| DOWN    | ← |   |

UNLESS OTHERWISE SPECIFIED ALL DIMENSIONS ARE IN MILLIMETERS AND TOLERANCES ARE AS BELOW PER ISO2768-cK.

| LINEAR |           | ANGLUR  |                 |
|--------|-----------|---------|-----------------|
| 0~3    | $\pm 0.2$ | 0~10    | $\pm 1.5^\circ$ |
| 3~6    | $\pm 0.5$ | 10~50   | $\pm 1^\circ$   |
| 6~30   | $\pm 0.8$ | 50~120  | $\pm 30'$       |
| 30~120 | $\pm 1.5$ | 120~400 | $\pm 15'$       |

|        |     |      |          |
|--------|-----|------|----------|
| DRAWN  | QHF | DATE | 20241211 |
| APPRVD |     | DATE |          |

**DINGS**

MODEL VC-30-13-4.63-000

|       |      |       |        |
|-------|------|-------|--------|
| SIZE  | A3   | SHEET | 1 OF 1 |
| SCALE | Free | REV   | 00     |

